

# ArcGIS<sup>®</sup> 9

Using ArcMap<sup>™</sup>

---



Copyright © 2000–2004 ESRI  
All rights reserved.  
Printed in the United States of America.

The information contained in this document is the exclusive property of ESRI. This work is protected under United States copyright law and other international copyright treaties and conventions. No part of this work may be reproduced or transmitted in any form or by any means, electronic or mechanical, including photocopying and recording, or by any information storage or retrieval system, except as expressly permitted in writing by ESRI. All requests should be sent to Attention: Contracts Manager, ESRI, 380 New York Street, Redlands, CA 92373-8100, USA.

The information contained in this document is subject to change without notice.

#### DATA CREDITS

*Quick-Start Tutorial Data:* Wilson, North Carolina.

*Population Density—Conterminous United States Map:* U.S. Department of Census.

*The African Landscape Map:* Major Habitat Types—Conservation Science Program, WWF-US; Rainfall—ArcAtlas™, ESRI, Redlands, California; Population data from EROS Data Center USGS/UNEP.

*Amazonia Map:* Conservation International.

*Forest Buffer Zone—100 Meters Map:* U.S. Forest Service (Tongass Region).

*Horn of Africa Map:* Basemap data from ArcWorld™ (1:3M), ESRI, Redlands, California; DEM and Hillshade from EROS Data Center USGS/UNEP.

*Mexico:* ESRI Data & Maps CDs, ESRI, Redlands, California.

*Mexico: 1990 Population:* ESRI Data & Maps CDs, ESRI, Redlands, California.

*Population Density in Florida (2001):* ESRI Data & Maps CDs, ESRI, Redlands, California.

*Rhode Island, the Smallest State in the United States:* Elevation data from the USGS, EROS Data Center; other data from ESRI Data & Maps CDs, ESRI, Redlands, California.

*Countries of the European Union:* Member States and Candidate Country information from EUROPA (The European Union On-Line); ESRI Data & Maps CDs, ESRI, Redlands, California.

*Mexico Population Density Map:* ESRI Data & Maps CDs, ESRI, Redlands, California.

*Health Care in the United States Map:* Population data from U.S. Department of Census; Health Service Areas from the trustees of Dartmouth College; Service Providers data from Healthcare Financing Administration.

*Clark County Land Use Map:* Clark County Office, Washington State.

*Southeast Asia Population Distribution Map:* ArcWorld (1:3M), ESRI, Redlands, California.

*Global 200—World's Biologically Outstanding Ecoregions Map:* Ecoregions data from Conservation Science Program, WWF-US; Country boundaries from ArcWorld (1:3M), ESRI, Redlands, California.

*Australia Map:* Major Habitat Types data from Conservation Science Program, WWF-US; Basemap from ArcWorld (1:3M), ESRI, Redlands, California.

*New Hampshire Telecom Map:* Geographic Data Technology, Inc.

*Redlands Image:* Courtesy of Emerge, a division of TASC.

#### CONTRIBUTING WRITERS

Melanie Harlow, Rhonda Pfaff, Michael Minami, Alan Hatakeyama, Andy Mitchell, Bob Booth, Bruce Payne, Cory Eicher, Eleanor Blades, Ian Sims, Jonathan Bailey, Pat Brennan, Sandy Stephens, Simon Woo

#### U.S. GOVERNMENT RESTRICTED/LIMITED RIGHTS

Any software, documentation, and/or data delivered hereunder is subject to the terms of the License Agreement. In no event shall the U.S. Government acquire greater than RESTRICTED/LIMITED RIGHTS. At a minimum, use, duplication, or disclosure by the U.S. Government is subject to restrictions as set forth in FAR §52.227-14 Alternates I, II, and III (JUN 1987); FAR §52.227-19 (JUN 1987) and/or FAR §12.211/12.212 (Commercial Technical Data/Computer Software); and DFARS §252.227-7015 (NOV 1995) (Technical Data) and/or DFARS §227.7202 (Computer Software), as applicable. Contractor/Manufacturer is ESRI, 380 New York Street, Redlands, CA 92373-8100, USA.

ESRI, the ESRI globe logo, ArcInfo, ArcEditor, ArcView, ArcMap, ArcCatalog, ArcGIS, ArcReader, ArcAtlas, ArcWorld, ArcSDE, SDE, Spatial Database Engine, ArcObjects, PC ARC/INFO, ArcIMS, ArcPress, ArcToolbox, GIS by ESRI, the ArcGIS logo, Geography Network, the Geography Network logo, www.geographynetwork.com, and www.esri.com are trademarks, registered trademarks, or service marks of ESRI in the United States, the European Community, or certain other jurisdictions.

The Microsoft Internet Explorer logo is a trademark of Microsoft Corporation.

Other companies and products mentioned herein are trademarks or registered trademarks of their respective trademark owners.

# Quick-start tutorial

# 2

## IN THIS CHAPTER

- **Exercise 1: Exploring your data**
- **Exercise 2: Working with geographic features**
- **Exercise 3: Working with tables**
- **Exercise 4: Editing features**
- **Exercise 5: Working with map elements**

The best way to learn ArcMap is to try it yourself. This tutorial guides you through some basic ArcMap skills as you create and print a set of maps for a county that is planning to expand its airport.

Residents of the county have identified several issues they are concerned about. These include noise affecting schools and houses near the airport and increased traffic along major roads. In this tutorial, you'll first create and print a map showing schools near the airport. Then you'll place this map—along with two other maps that show land use surrounding the airport and population density for the county—on a wall-sized poster for display.

In the tutorial, you'll learn how to:

- Display map features.
- Add data to your map.
- Edit geographic data.
- Work with data tables.
- Query and select geographic features.
- Create a summary chart.
- Lay out and print a map.

There are five exercises. Each exercise takes between 30 and 45 minutes to complete. You can work through the entire tutorial or complete each lesson one at a time.

## Exercise 1: Exploring your data

In this exercise, you'll create a map showing locations of schools near the airport, along with a noise contour, to see which schools may be affected by noise from the airport. The noise contour is based on the 65 Community Noise Equivalency Level (CNEL), which indicates areas experiencing more than 65 decibels of noise, averaged over a 24-hour period. In many cases, buildings within the 65 CNEL will need soundproofing or other mitigation measures.

The exercises in this chapter use the tutorial data distributed with ArcMap. The default install location of the data is C:\ArcGIS\ArcTutor\Map. The exercises require that you have write access to this data. If you don't, you'll need to copy the data to a location that you do have write access to.

### Starting ArcMap

ArcMap lets you explore your geographic data and create maps for display.

1. Click the Start button on the Windows taskbar.
2. Point to Programs.
3. Point to ArcGIS.
4. Click ArcMap.

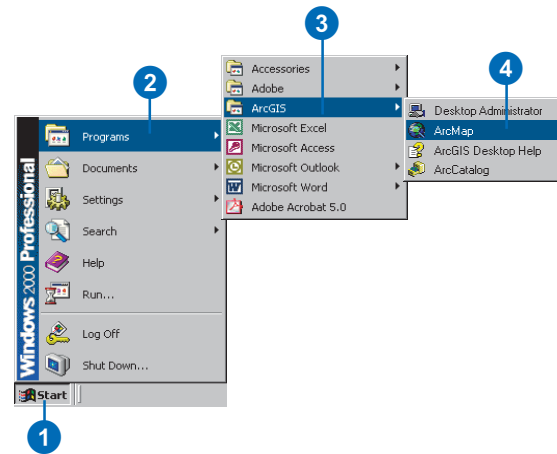

### Opening an existing map document

The first time you start ArcMap, the Startup dialog box appears. The Startup dialog box offers you several options for starting your ArcMap session. For this exercise, you want to open an existing map document.

1. Double-click Browse for maps. If this is not the first time ArcMap has been started and the Startup dialog box does not appear, click File on the Main menu and click Open.

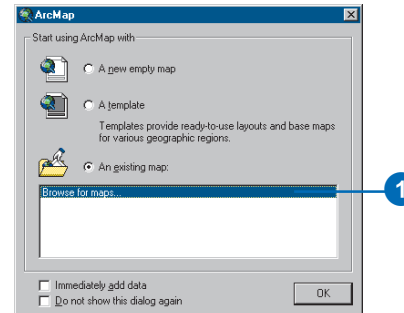

- In the dialog box, click the Look in dropdown arrow, and navigate to the Map folder on the local drive where you installed the tutorial data (the default installation path is C:\ArcGIS\ArcTutor\Map).
- Double-click airport.mxd. ArcMap opens the map.

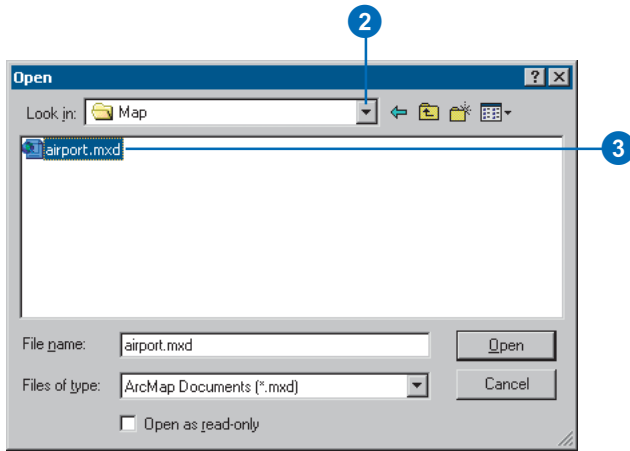

ArcMap stores a map as a map document (.mxd) so you can redisplay it, modify it, or share it with other ArcMap users. The map document doesn't store the actual data, but rather references the data stored on disk along with information about how it should be displayed. The map document also stores other information about the map, such as its size and the map elements it includes (title, scalebar, and so on).

To the left of the ArcMap display window is the table of contents, showing you which geographic layers are available to display. To the right is the map display area.

Table of contents

Map display area

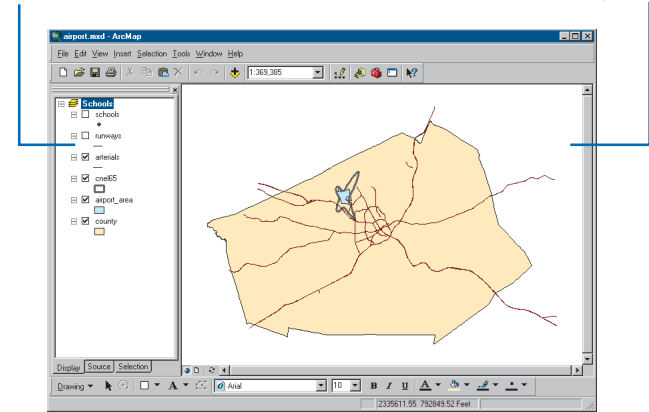

This particular map contains the following layers in a data frame called Schools:

schools	locations of elementary, middle, high, and private schools
runways	location of airport runways
arterials	major roads
cnel65	the noise contour
airport_area	the proposed airport expansion zone
county	the county boundary

The map currently displays the arterials, noise contour, airport area, and county boundary. Their boxes are checked in the table of contents.

## Moving around the map

The Tools toolbar lets you move around the map and query the features on the map. Place your pointer over each icon (without clicking) to see a description of each tool.



1. Using the Zoom In tool, draw a box around the noise contour to zoom in. Place the pointer on the upper-left part of the contour, press the mouse button, and hold it down while dragging to the lower right. You'll see the box drawn on the screen. When you release the mouse button, ArcMap zooms in to the area defined by the box.

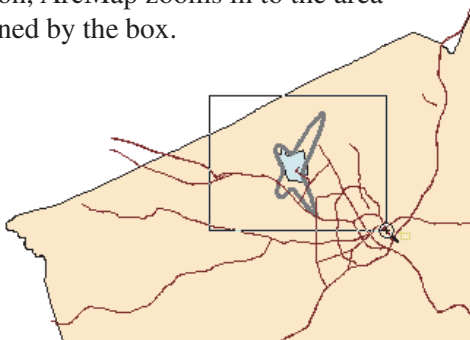

2. If necessary, use the Pan tool (the hand) on the Tools toolbar to reposition the map so the noise contour is in the center of the display area (hold the mouse button down while dragging in the direction you want to move the features, then release the button).

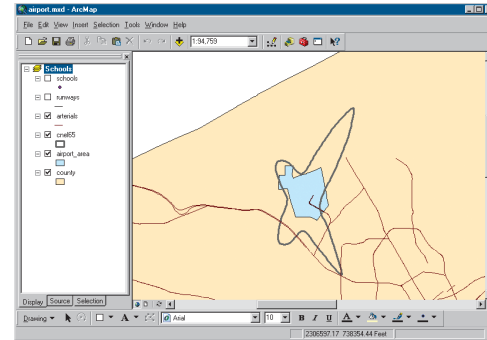

## Displaying a layer

The table of contents lets you turn layers on and off in the display. To display a layer, check the box next to its name. To turn it off, uncheck it. Display the schools and runways by checking their boxes in the table of contents. For more information, see Chapter 5, 'Working with layers'.

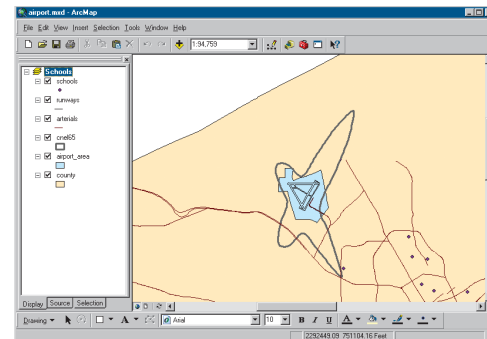

## Changing the display symbol

ArcMap lets you change the colors and symbols you use to display features. You'll change the symbols for schools from a dot to a standard symbol used for schools on many maps.

1. Click the dot symbol in the table of contents to display the Symbol Selector window.

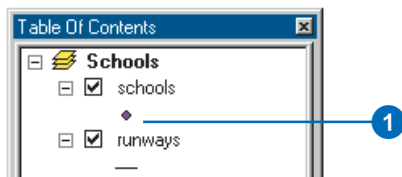

2. Scroll down until you find the School 1 symbol. Click it.

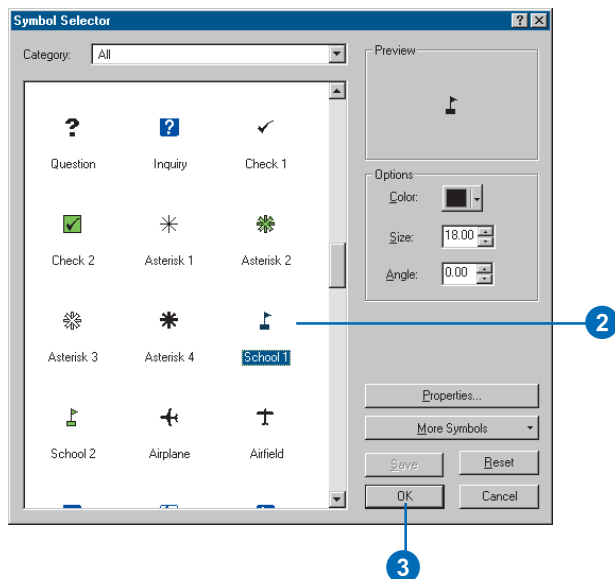

3. Click OK. The schools are drawn with the new symbol.

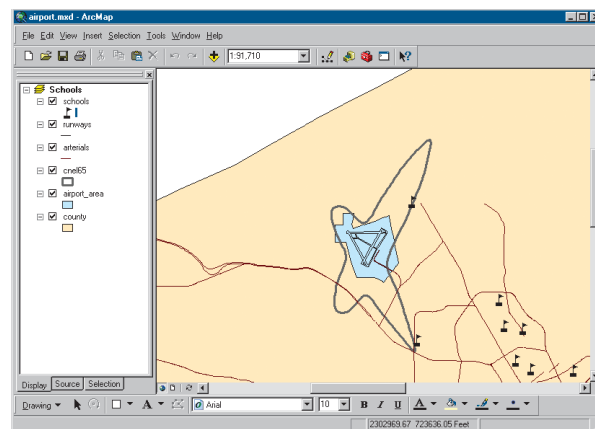

You can also open the symbol dialog box by right-clicking the layer name, choosing Properties from the menu that appears, and clicking the Symbology tab. To simply change the color of a symbol, right-click the symbol in the table of contents to display the color palette. For more information on changing display symbols, see Chapter 6, 'Symbolizing features'.

## Identifying a feature

There is one school that may be within the noise contour around the airport.

1. Using the Zoom In tool, draw a box around the school to zoom in.

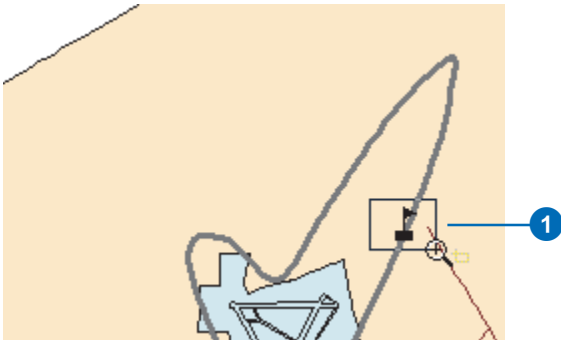

You can see that the school is indeed within the noise contour.

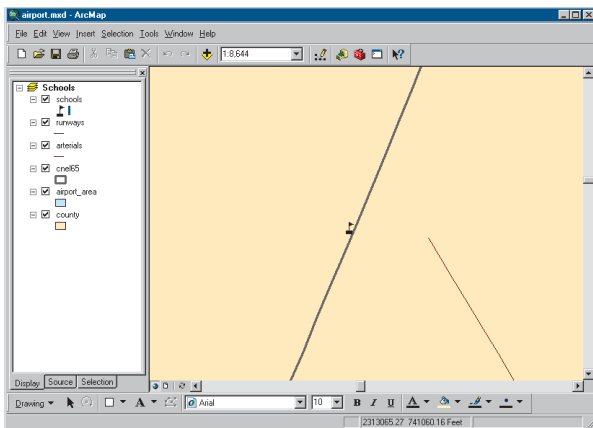

2. Click the Identify tool on the Tools toolbar. The Identify Results window appears.



3. Move the mouse pointer over the school and click. The name of the school (Northwestern Prep) is listed in the Identify Results window. Notice that only the features in the topmost layer are identified. You can also identify features in other layers by choosing the specific layers you want to identify by clicking the Layers dropdown arrow in the dialog box.

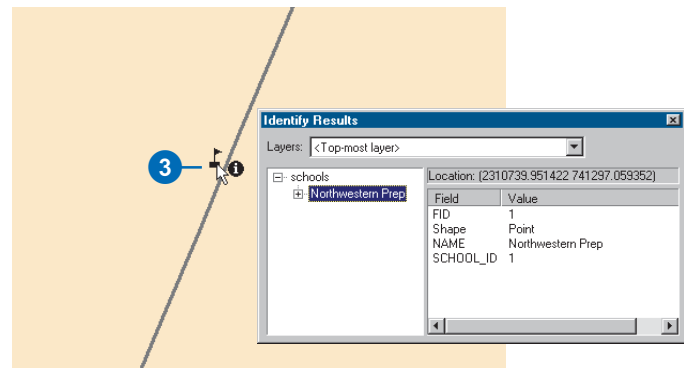

Close the Identify Results window.



- Click the Back button on the Tools toolbar to return to your previous view.

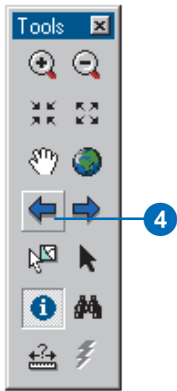

## Adding graphics

You can add text and other graphics to your display using the Draw toolbar at the bottom of the ArcMap window.

- Click the New Text button. The pointer changes to a crosshair with an A.



- Move the mouse pointer near the school you identified and click.
- In the text box that appears, type “Northwestern Prep” and press Enter.

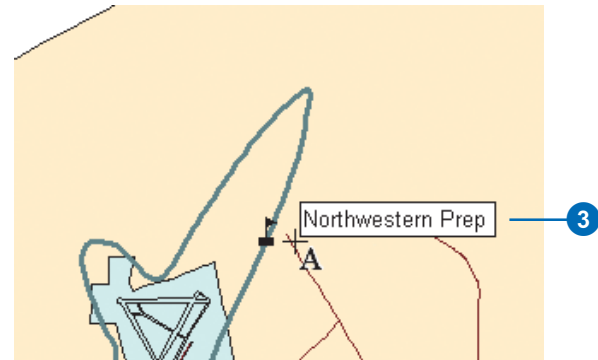

A blue dotted line surrounds the text, indicating it is currently selected. You can drag the text to a new position by clicking and holding down the mouse button while dragging the text, then releasing the button.



- When you’re finished positioning the text near the school, click outside the text box to deselect it.

For more information on working with text, see Chapter 7, ‘Working with graphics and text’.

## Laying out a map

ArcMap lets you work in data view or layout view. Data view focuses on a single data frame. Use data view when exploring or editing your data. Layout view shows you how the map page looks. Use layout view when composing and printing a map for display. You can also explore and edit your data in layout view if you want. All the tools and options available in data view are also available in layout view.

You can change the size and orientation of the page in layout view. In this case, you'll create a 16- by 12-inch map with a landscape orientation.

1. Click the Fixed Zoom Out button on the Tools toolbar several times to zoom to a smaller map scale.
2. Click the View menu and click Layout View. The Layout toolbar appears, and the display changes to show the page layout with rulers along the side.

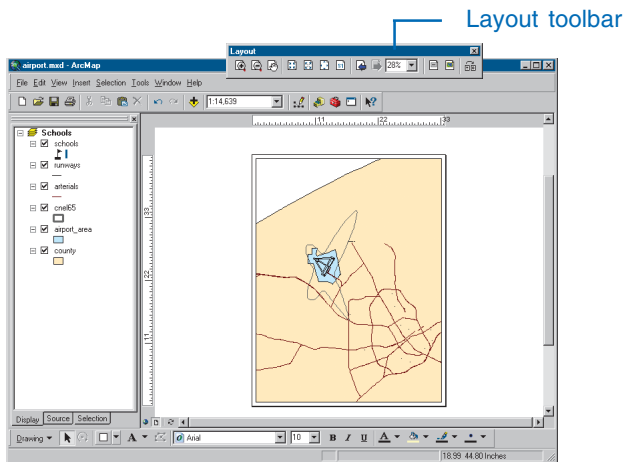

3. Right-click anywhere on the layout background and click Page and Print Setup. You can also access Page and Print Setup from the File menu.

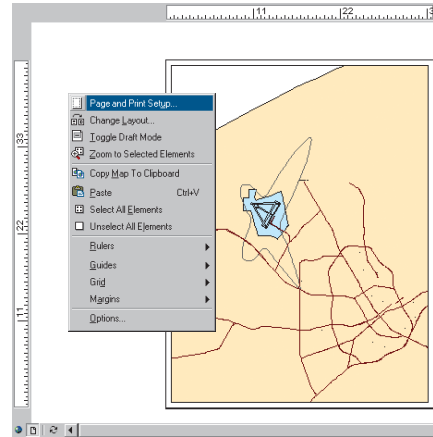

4. Make sure the Use Printer Paper Settings box is not checked—otherwise, the page size will default to be the same as your printer. If your printer does not print larger sizes, you can scale down the map when you print it, as you'll see later in this exercise.
5. Check Scale Map Elements proportionally to changes in Page Size. That way, the data will be rescaled to fit the page.
6. Set the Map Page Size Page Orientation to Landscape.
7. Set the page width to 16 and the height to 12 inches by clicking in each box and typing over the existing values.

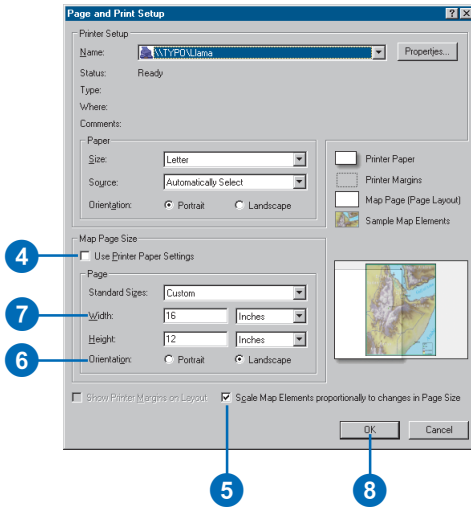

- Click OK. The page display and rulers change to reflect the new size and orientation. You may need to resize your data frame manually to make it look like the map below. To do this, click the Select Elements tool on the Tools toolbar, click the data frame, and resize the data frame using the blue selection handles.

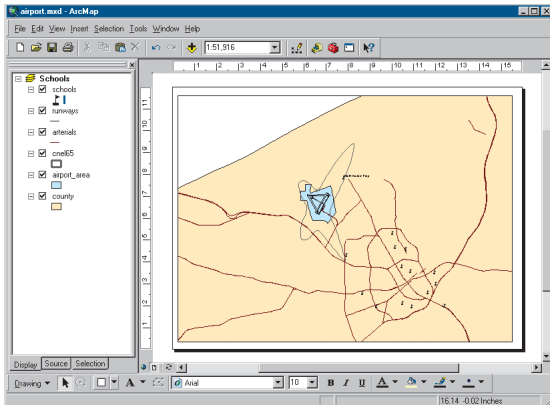

## Zooming in on the page

The Layout toolbar controls your view of the scale and position of the whole map (as opposed to the data layers on the map). By default, the map size is set so you can see all of it. But at this scale it's hard to see the school name.

- Click Zoom to 100% on the Layout toolbar. The page is displayed at the actual printed size so you can see the detail.

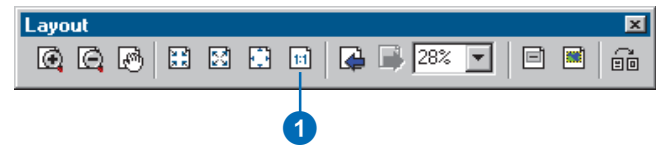

- Click the Pan button on the Layout toolbar and drag the map to the lower left so you can see the name of the school.

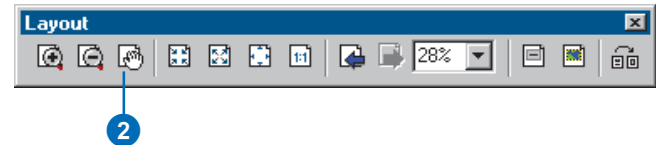

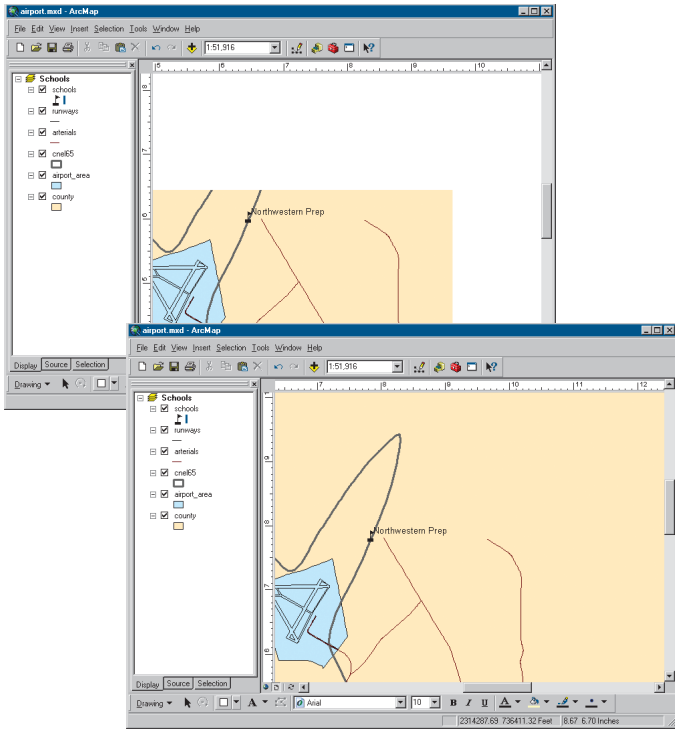

## Inserting map elements

ArcMap makes it easy to add titles, legends, North arrows, and scalebars to your map.

1. Click Insert on the Main menu and click Title. In the box that appears, type the title for your map, “Schools and Noise Contour”, and press Enter.

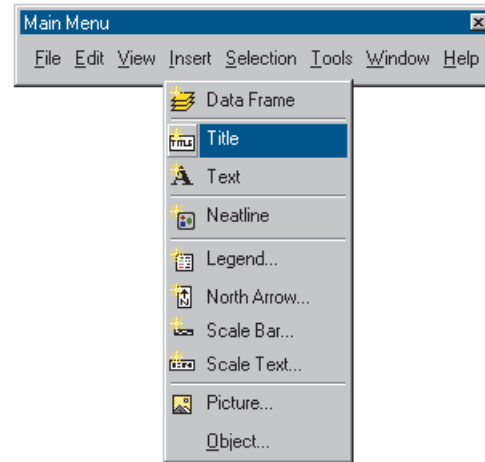

3. Click the Zoom Whole Page button on the Layout toolbar to see the entire page again.

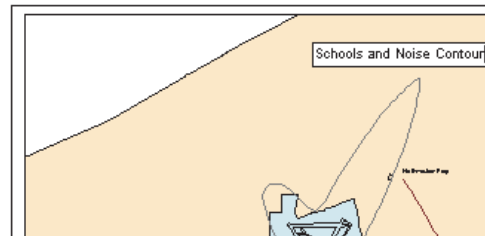
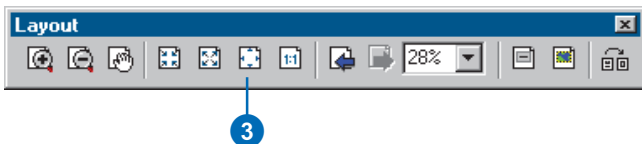

- On the Draw toolbar at the bottom of the window, click the Text Size dropdown arrow and click 36 to change the title to 36 point.

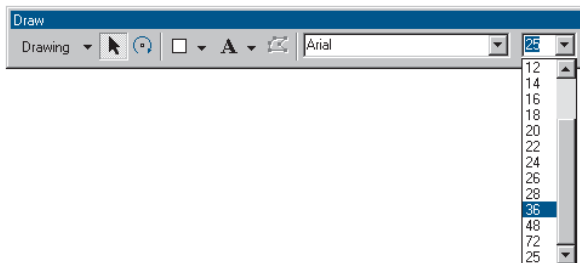

- Click the title and drag it so it's centered at the top of the map.

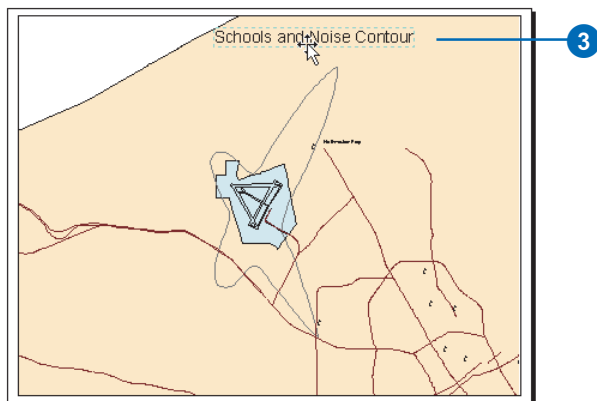

The Draw toolbar lets you add and change the format (font, size, color, and so on) of text and graphic elements—such as boxes, callout lines, or circles—on your map.

- Click Insert and click Legend.

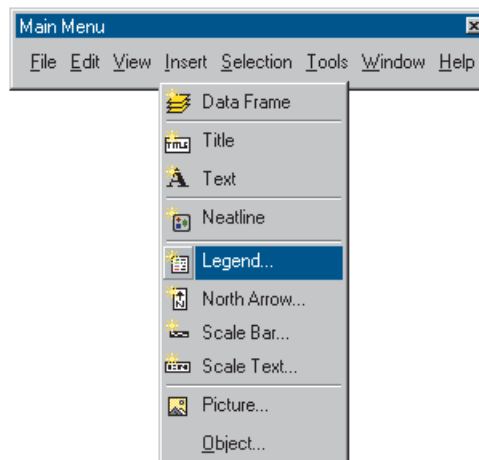

The Legend Wizard appears.

- Click Next several times to step through the wizard accepting the default legend parameters. Click Finish when done.

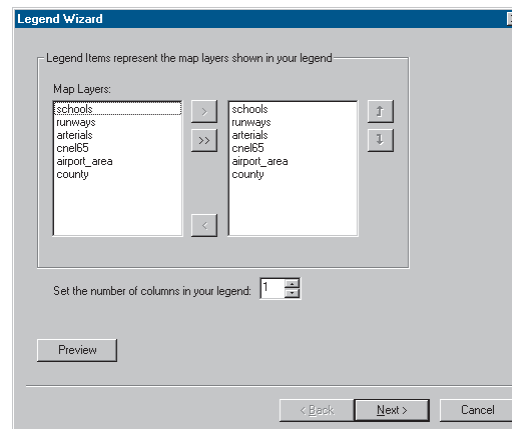

By default, ArcMap scales the legend to the page and includes all the layers that are currently displayed. You can modify the legend by right-clicking it and choosing Properties from the menu that appears. For now, just use the default legend.

- Click and drag the legend to the lower-left corner of the map.

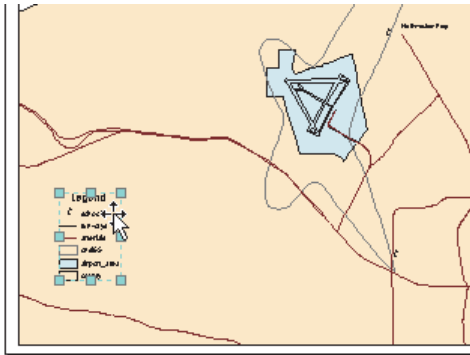

- Click Insert and click North Arrow. The North Arrow Selector window appears.

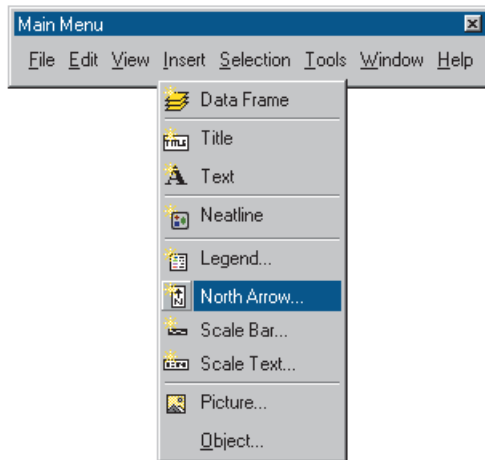

- Click ESRI North 1 and click OK. Click and drag the North arrow so it is to the right of the legend.

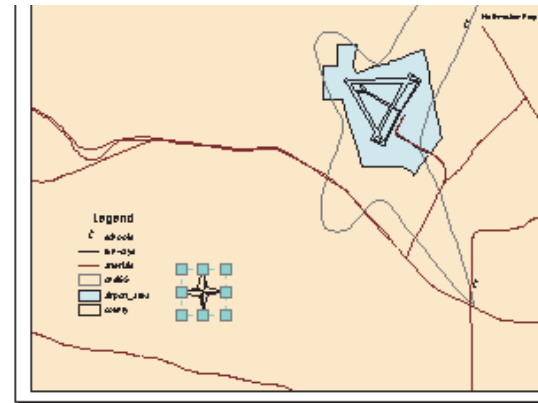
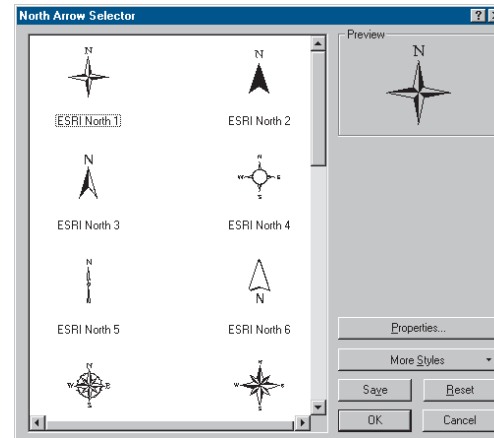

9. Now insert a scalebar from the Insert menu. Click Scale Line 1 in the Scale Bar Selector window and click OK.

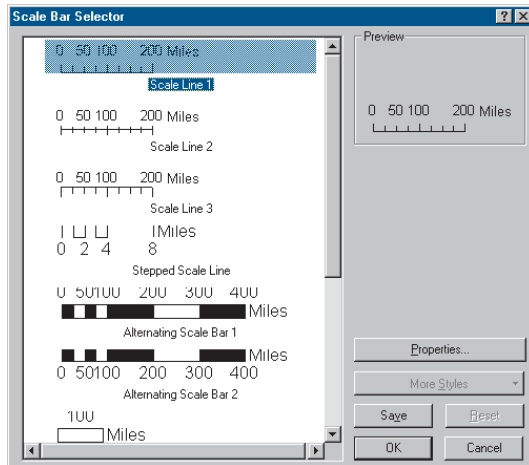
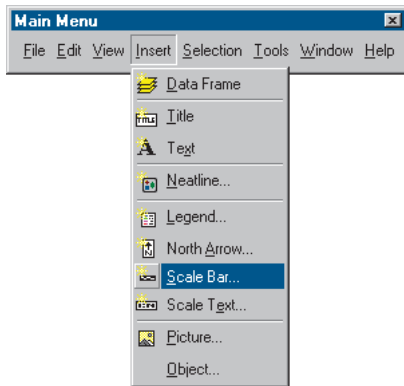

10. Click and drag the scalebar under the legend and North arrow.

11. Click the legend to select it; while holding down the Shift key, click the scalebar to select it as well.

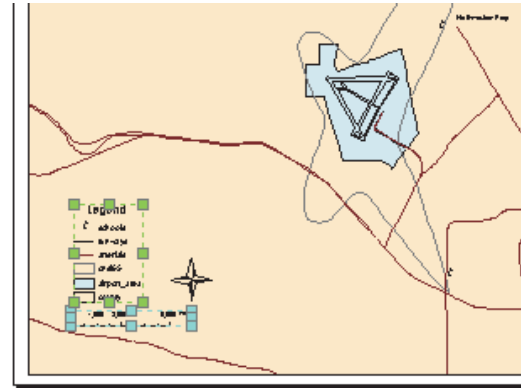

12. Click Drawing on the Draw toolbar, point to Align, and click Align Left from the menu that appears. The scalebar is now aligned with the left side of the legend.

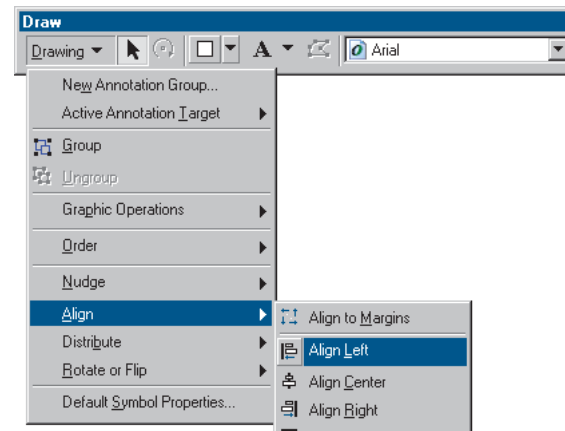

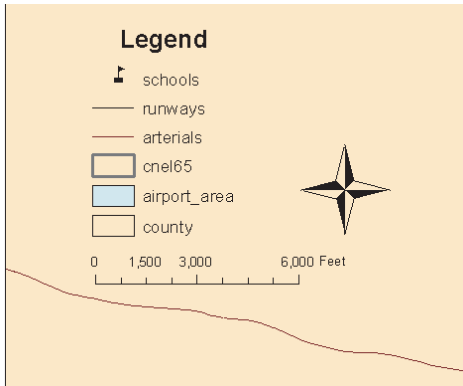

## Printing a map

At this point, your first map is finished. If you have a printer connected to your computer, you can print the map.

1. Click File and click Print.

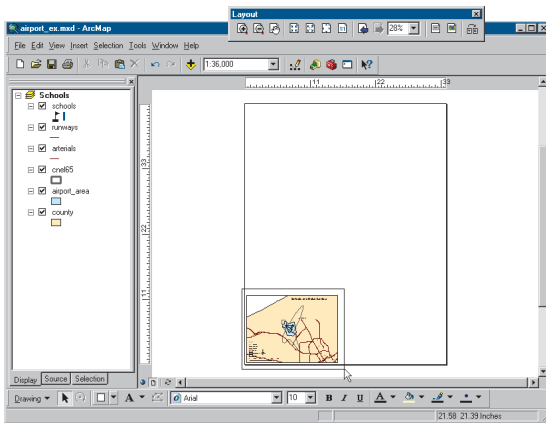

2. If the map (which is 16 by 12 inches) is larger than your printer paper, click Scale Map to fit Printer Paper.

3. Click Setup.

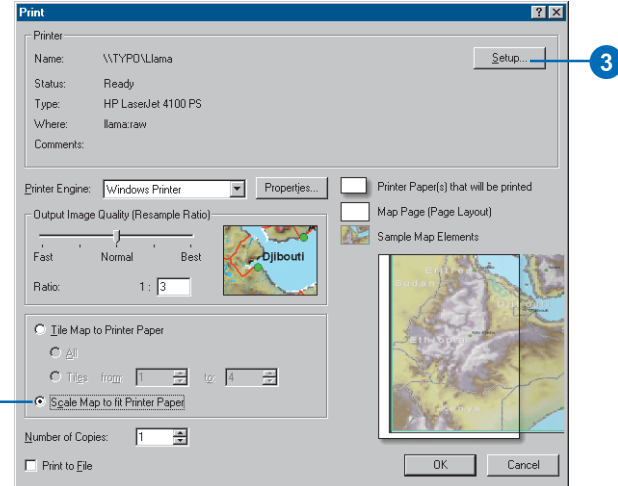

4. Click Landscape on the Printer Setup panel.

5. Click OK to close the Page and Print Setup dialog box.

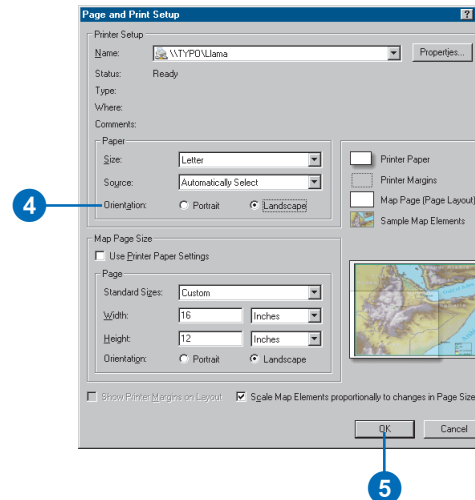



6. Click OK on the Print dialog box to print your map.

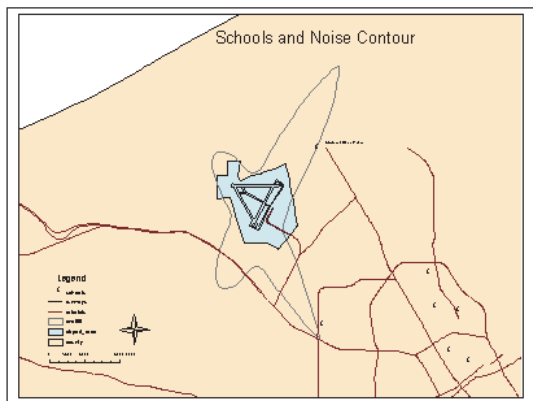

## Saving a map

Save your map in the folder with the tutorial data. First, though, ensure that ArcMap uses the full pathname of the location of the data on your system. The airport map was created using relative pathnames, so ArcMap would find and display the data after the ArcTutor\Map folder is copied to your system.

1. Click File and click Map Properties.
2. Click Data Source Options on the Properties dialog box.

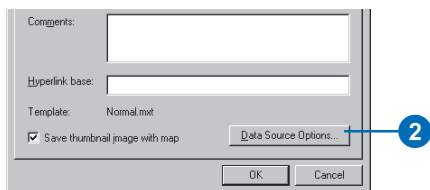

3. Click Store full path names and click OK.

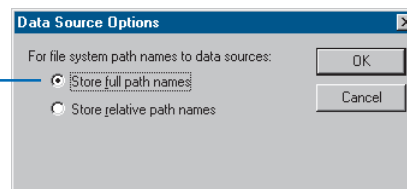

4. Click OK on the Map Properties dialog box.

Now save a copy of your map. You'll use this copy in the subsequent exercises.

1. Click File and click Save As.

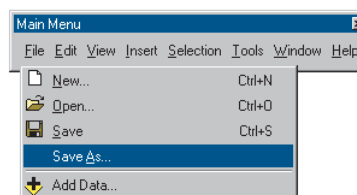

2. In the File name box, type "airport\_ex".
3. Click Save.

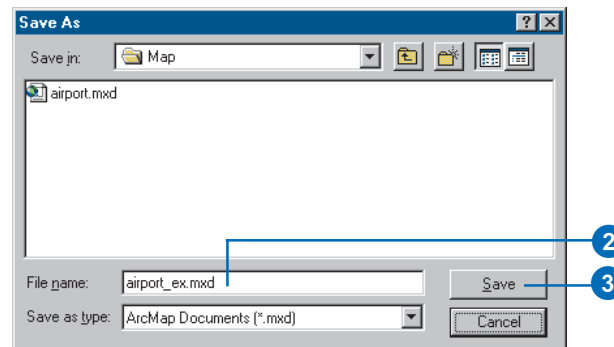

You can continue with the tutorial or stop and complete it at a later time.

## Exercise 2: Working with geographic features

In this exercise, you'll map the amount of each land use type within the noise contour. You'll add data to your map, draw features based on an attribute, select specific features, and summarize them in a chart.

If necessary, start ArcMap, navigate to the folder where you saved the map from Exercise 1 (airport\_ex), and open the map.

### Changing the page layout

First, you'll create the map layout by changing the page size and orientation.

1. Make sure you're in layout view (click the View menu and click Layout View).

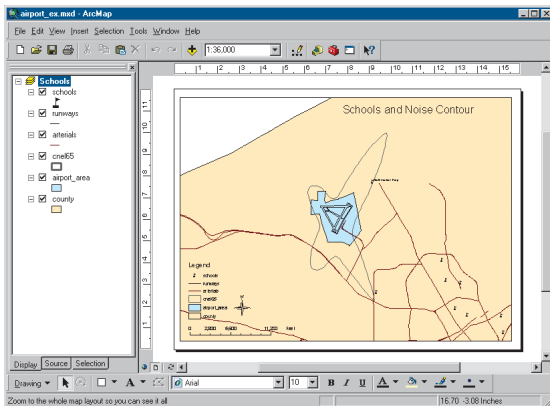

2. Click File and click Page and Print Setup.

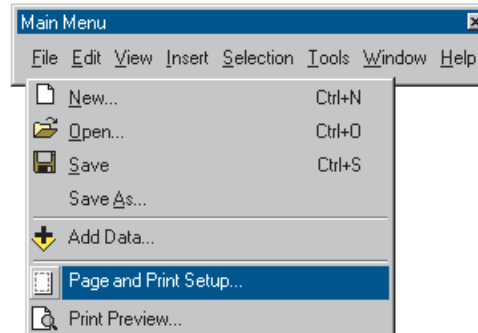

3. Click the Standard Sizes dropdown arrow and click ANSI E. That sets the width and height to a standard E-size page.
4. Click Portrait on the Map Page Size panel.
5. Uncheck Scale Map Elements proportionally to changes in Page Size (this way, the existing map of schools will remain the same size, rather than being scaled up to fit the page).

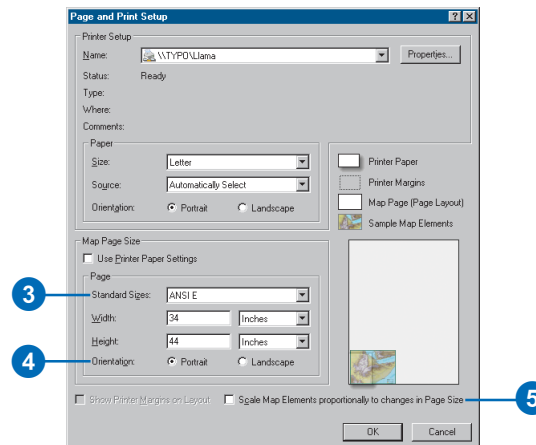

6. Click OK. The page size changes, and the existing map is displayed in the lower-left corner.

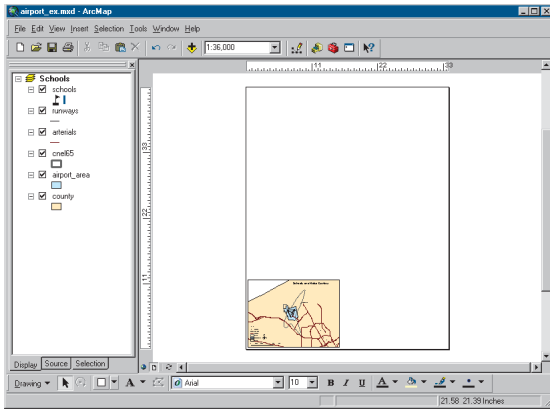

7. Click the Select Elements tool on the Tools toolbar.

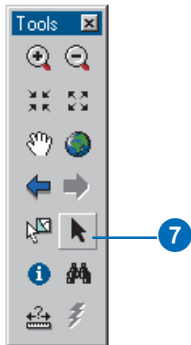

8. Click and drag a box around the elements to select them.

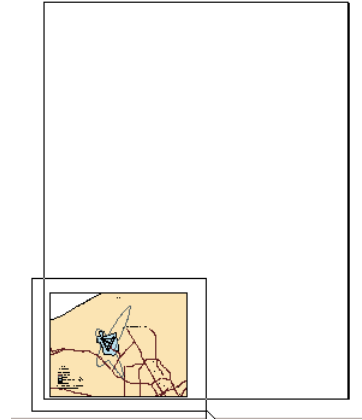

9. Click and drag the group of elements to the upper portion of the page.

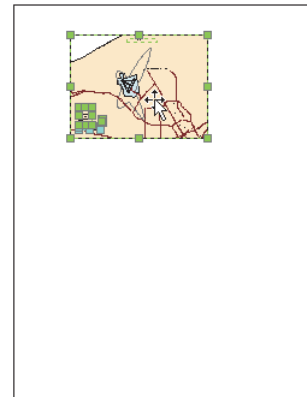

For more information on page layout, see Chapter 15, 'Laying out and printing maps'.

## Creating a new data frame

A data frame is a way of grouping a set of layers you want to display together. Now you'll add a new data frame to show land use.

1. Click Insert and click Data Frame.

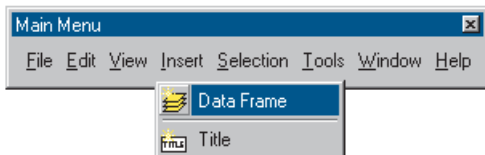

The frame appears on the layout and is listed in the table of contents.

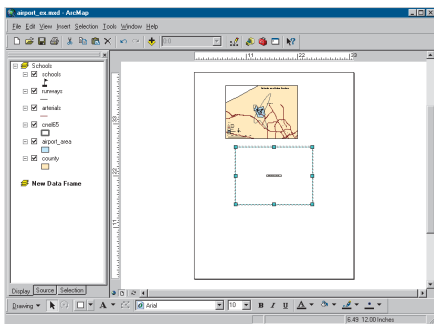

## Adding a data layer

You'll map land use based on a code for each land parcel. First, add the parcels layer to the data frame.

1. Click the New Data Frame data frame on the page so only it is selected.

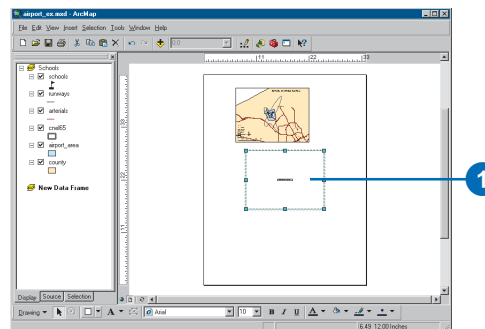

2. Click the Add Data button on the Standard toolbar.



3. Navigate to the Map folder on the local drive where you installed the tutorial data (the default installation path is C:\ArcGIS\ArcTutor\Map).
4. Double-click the airport geodatabase, airport.mdb.
5. Click the parcels layer and click Add.

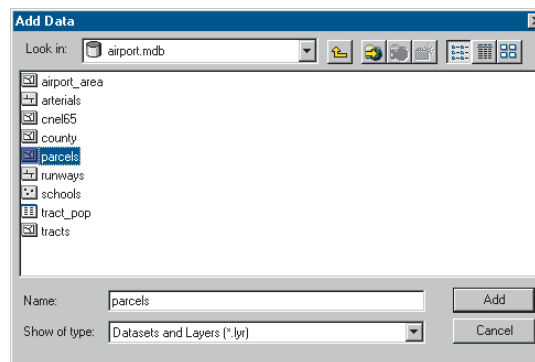

The data layer is added to the table of contents and displays in the layout (the parcels may be a different color on your map).

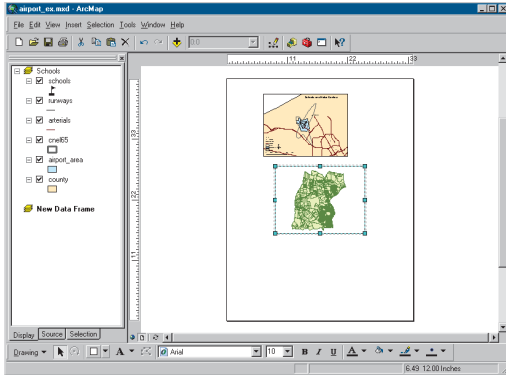

All the data used in this tutorial is stored in a geodatabase. ArcMap also lets you work with ArcInfo™ coverages, shapefiles, image files, and many other data formats. For more about geodatabases and other data formats, see *Using ArcCatalog*.

### Setting properties of the data frame

1. Right-click New Data Frame in the table of contents and click Properties. You may need to hold your pointer over the arrow at the bottom of the menu to see Properties in the list.

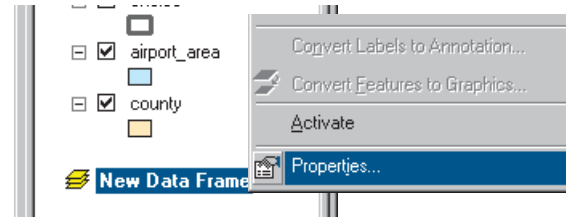

2. Click the General tab, highlight the existing text in the Name text box, and type “Land Use”.
3. Click the Display dropdown arrow and set the display units to Feet. You can’t change the map units because they are based on the data frame’s coordinate system.
4. Click Apply.
5. Click the Size and Position tab.

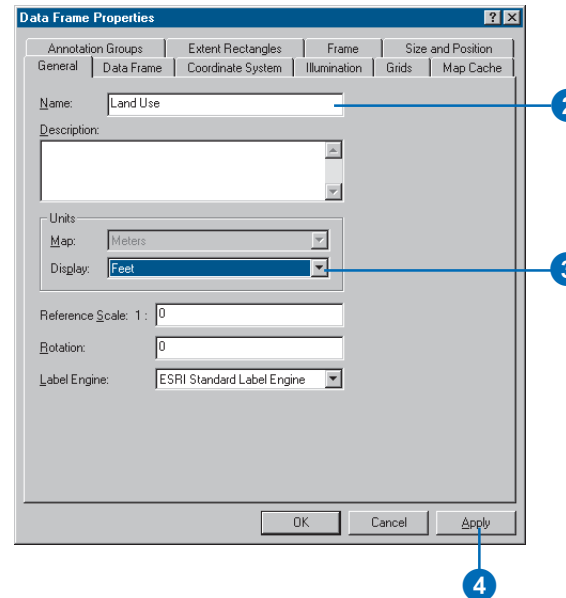

- Set the X position to 15 and the Y position to 15 by typing in the text boxes. This sets how far the lower-left corner of the data frame is, in inches, from the lower-left corner of the page. (You can specify X,Y position for another location on the data frame by clicking the appropriate box on the diagram.)

You can specify the position of any object on the page—the data frame itself, text, legends, and so on—either by

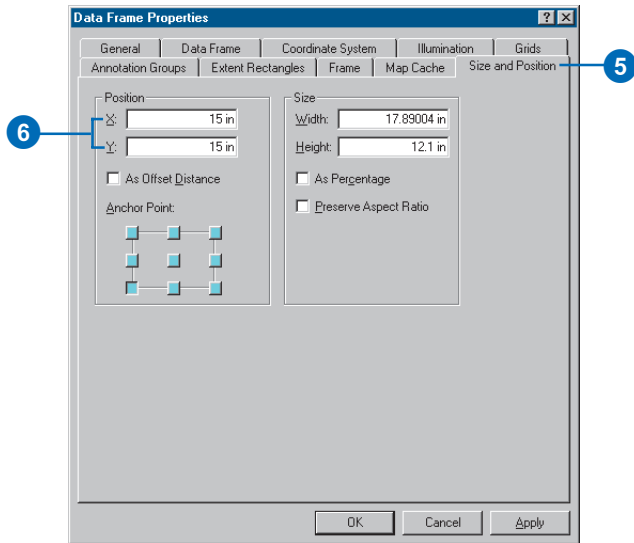

selecting and dragging them or by setting the X and Y position explicitly.

- Click OK. The data frame is repositioned.
- The data frame is highlighted with a blue square, and its name is bold in the table of contents, indicating it is the frame you're currently working with.
- Hold down the Shift key and click the top data frame on the page so both frames are selected.

- Click Drawing on the Draw toolbar, point to Distribute, and click Make Same Size.

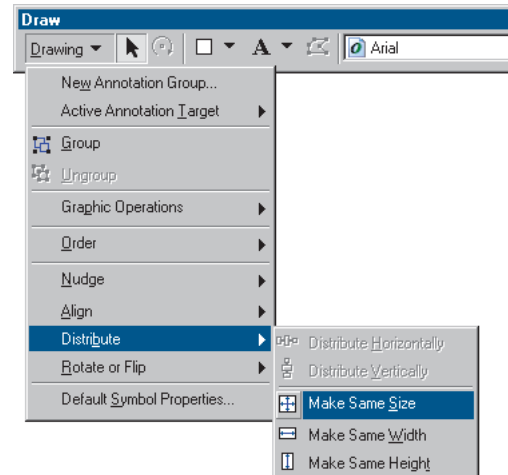
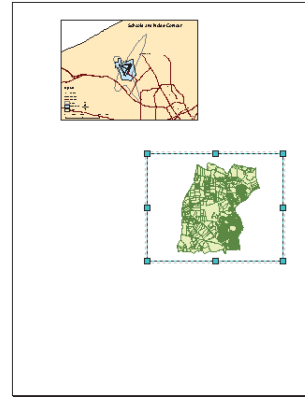



Both data frames are now the same size. Click the Land Use data frame on the page so it is the only data frame selected.

### Copying a layer

You'll want to display the noise contour and airport area with the parcels. You can copy them from the Schools data frame. First, though, switch back to data view.

1. Click the View menu and click Data View. Now you're looking at only the area covered by the parcels, rather than the entire map.

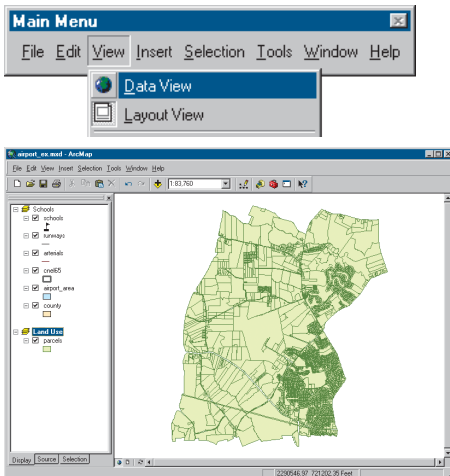

2. In the table of contents, right-click the airport\_area layer under the Schools data frame and click Copy.

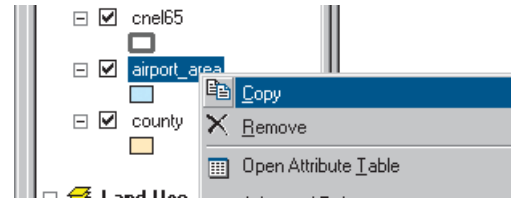

3. Right-click the Land Use data frame and click Paste Layer(s).

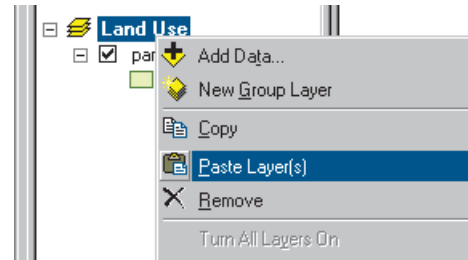

4. Copy the cnel65 layer the same way.

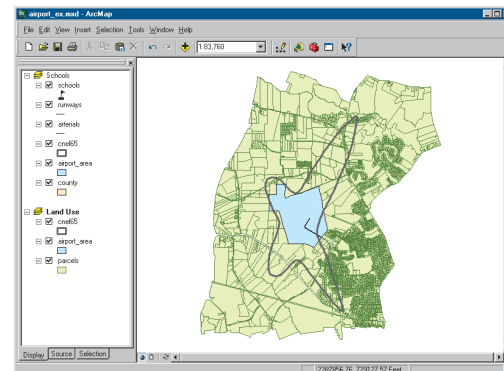

## Displaying features by category

By default, all the parcels are drawn using the same symbol when you add them. You can also draw them based on an attribute (in this case, type of land use).

1. Right-click parcels in the table of contents and click Properties.

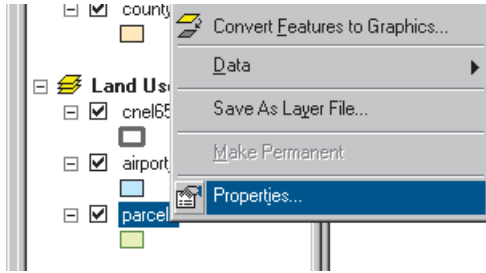

2. Click the Symbology tab. All parcels are currently drawn using the same symbol (the same solid fill color).
3. Click Categories in the Show box. Unique values is automatically highlighted.
4. Click the Value Field dropdown arrow and click LAND\_USE as the field to use to shade the parcels.
5. Click Add All Values. A unique color is assigned to each land use type.

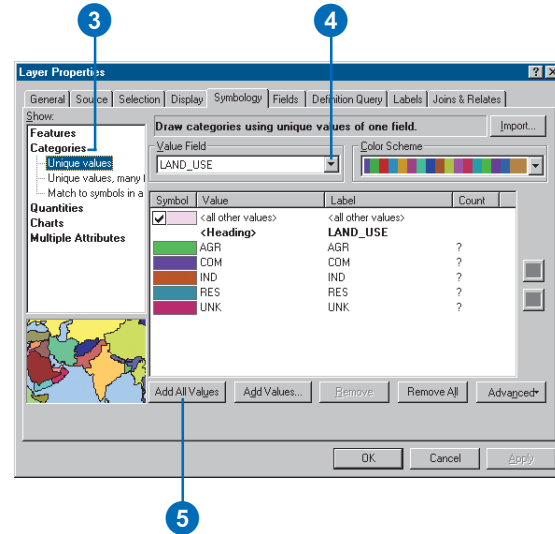

6. Click OK. The parcels are now drawn based on their land use type.

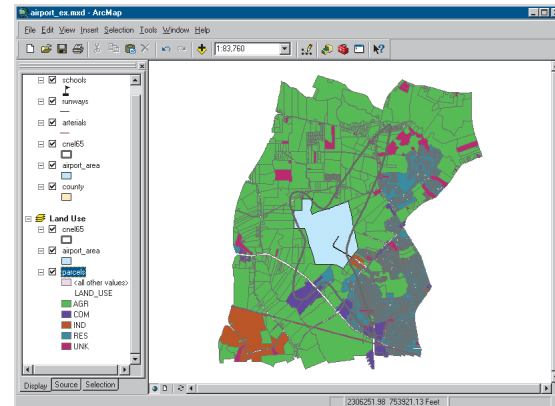



## Using a style

ArcMap uses a random set of symbols to draw the land use types (although you can change the color scheme). You can change an individual color by double-clicking it and specifying a new color in the Symbol Selector, or you can specify a style to use predefined colors and symbols (a style is a set of elements, symbols, and properties of symbols stored in ArcMap, often specific to an application or industry). ArcMap provides some standard styles, and you can also create your own. You'll use a land use style created for this tutorial.

1. Right-click parcels in the table of contents and click Properties.
2. Click the Symbology tab.
3. Under Categories in the Show window, click Match to symbols in a style.
4. Click the Browse button and navigate to the Map folder on the local drive where you installed the tutorial data (the default installation path is C:\ArcGIS\ArcTutor\Map). Click the land\_use style and click Open.
5. Click Match Symbols.
6. Click the check box to deselect and turn off the symbol displayed for <all other values>.

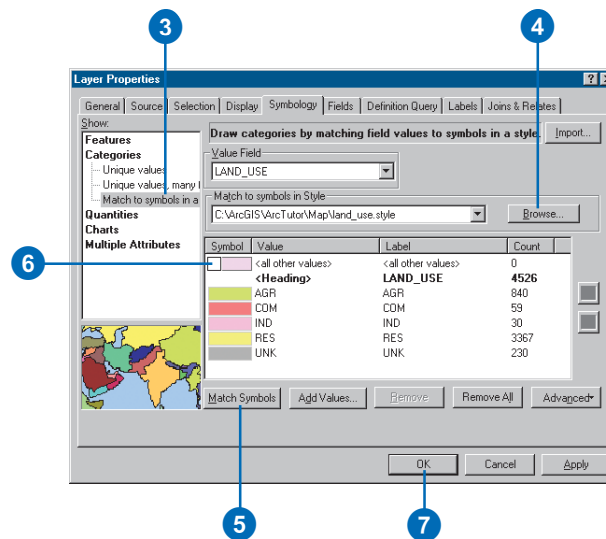

7. Click OK. The parcels will now be drawn using colors defined in the style.

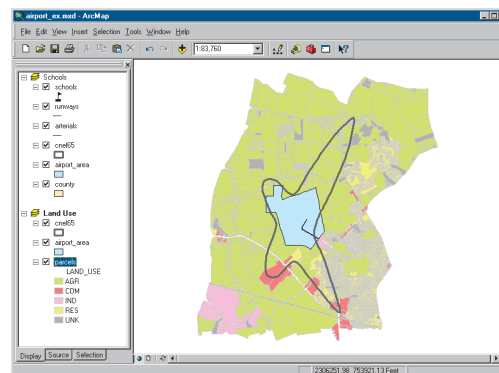

For more information on symbolizing and displaying features, see Chapter 6, 'Symbolizing features' and Chapter 8, 'Working with styles and symbols'.

## Selecting features geographically

To find out how much of each land use is within the noise contour, select only those parcels within the contour.

1. Click Selection and click Select By Location.

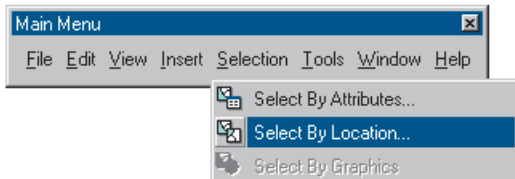

The Select By Location dialog box guides you through creating a geographic query.

2. In the first box, click the dropdown arrow and click select features from.
3. In the second box, check parcels as the layer to select features from.
4. Click the dropdown arrow for the third box and click intersect. This will select those features in parcels that intersect the features of cnel65.
5. In the last box, click the dropdown arrow and click cnel65 as the layer to select by.
6. Click Apply. The selected parcels are outlined in a thick line.

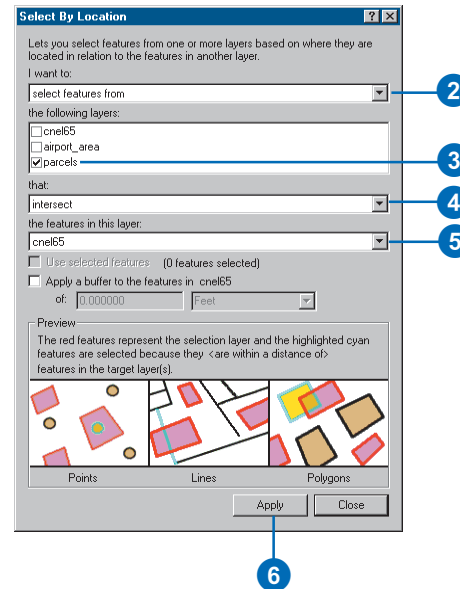

7. Close the Select By Location dialog box. Notice that any parcel even partially inside the contour is included.

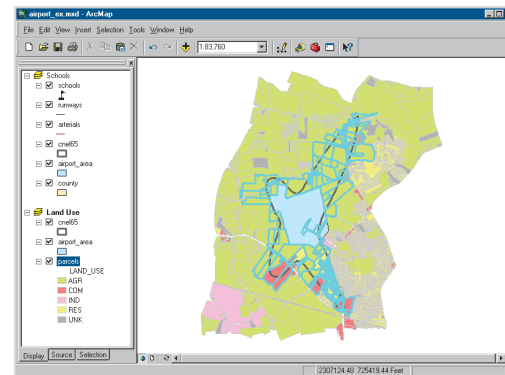

For more on selection, see Chapter 13, 'Querying maps'.

## Exporting a layer

To find out how many parcels and how much land area of each land use type are within the noise contour, you'll create a new feature class and run statistics on its data table.

1. Right-click parcels in the table of contents, point to Data, then click Export Data.

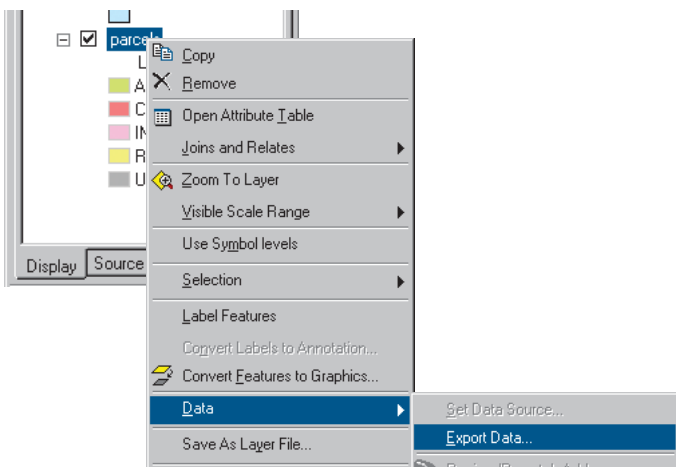

2. In the Export Data dialog box, click the Export dropdown arrow and click Selected features (to export only the selected parcels).
3. Save the selected features in the airport geodatabase as a feature class called parcels\_sel. Type the path as shown below, substituting the install location of the tutorial data on your system. (The default installation path for the geodatabase is C:\ArcGIS\ArcTutor\Map\airport.mdb.)

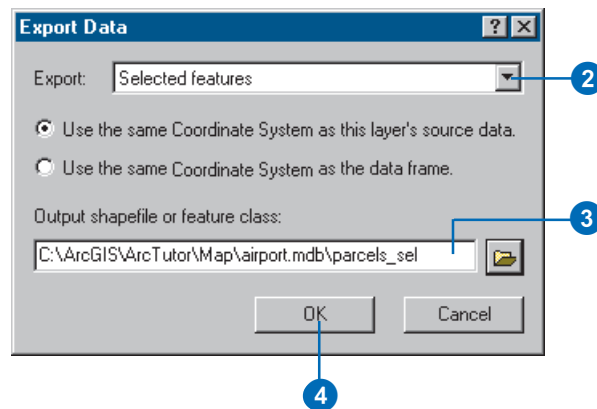

4. Click OK. ArcMap exports the parcels to a new feature class in the airport geodatabase.
5. Click Yes when prompted to add the exported data as a new layer on the map. The new layer contains only the selected parcels.
6. Right-click the original parcels layer, point to Selection, then click Clear Selected Features.

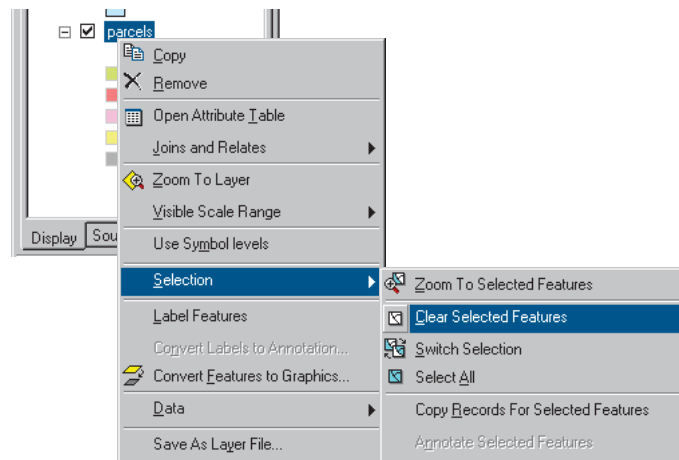

- The new layer is displayed on top of the other layers. To see the noise contour and airport area, click parcels\_sel in the table of contents and drag it down until the bar is above parcels. Then release the mouse button.

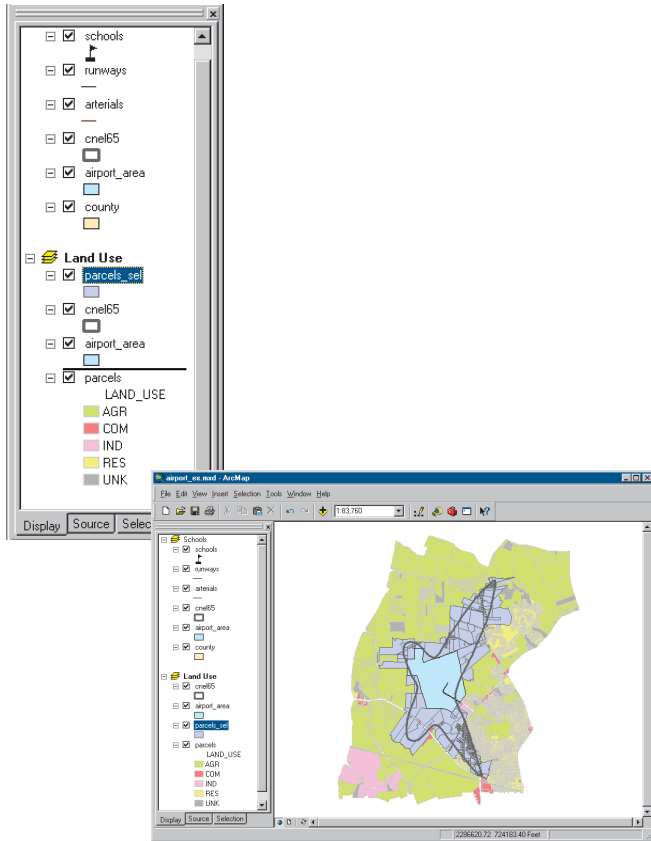

## Creating summary statistics

ArcMap includes tools for statistical analysis. You'll create a table to summarize the number of parcels of each land use type within the noise contour and the total area of each type.

- In the table of contents, right-click the parcels\_sel layer and click Open Attribute Table.

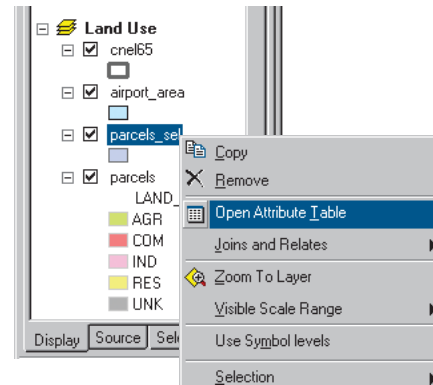

- Right-click the LAND\_USE field header and click Summarize.

FID*	Shape*	PARCEL_ID	LAND_USE	Shape_Length	Shape_Area
1	Polygon	275D0020003	AGR	762.060738	
2	Polygon	275D0020002	AGR	097.156159	
3	Polygon	275D0020001	AGR	468.319592	
4	Polygon	275D0010007	AGR	957.497676	
5	Polygon	275D0010001	AGR	024.909162	
6	Polygon	275D0010006	AGR	671.348813	

3. Make sure the field to summarize is LAND\_USE.
4. Click the plus sign next to Shape\_Area to expand it. Check Sum to summarize the area by land use type.
5. Create the output table in the airport geodatabase and name it lu\_frequency.
6. Click OK. ArcMap creates a new table with a record for each land use type showing the number of parcels of that type and the total land area (in square feet).
7. Click Yes when prompted to add the resulting table to the map. Close the parcels\_sel attribute table.

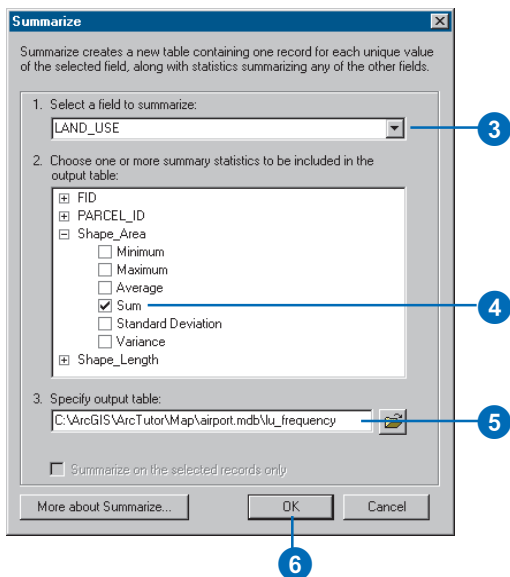

## Opening a table

You may have noticed that when the table is added to the map, the table of contents switches from the Display tab to the Source tab (at the bottom of the table of contents). The Source tab shows the location of all data in the table of contents; this is useful when editing data in ArcMap because it shows you which layers are in the same workspace. (When you edit in ArcMap, you edit an entire workspace; that is, all the layers in the workspace are available for editing.) The Source tab also lists all tables. Tables don't show up when the Display tab is selected since a table is not a geographic feature that gets displayed on the map.

1. Right-click lu\_frequency in the table of contents and click Open. You can see the number of parcels and the total area (in square feet) of each land use type.

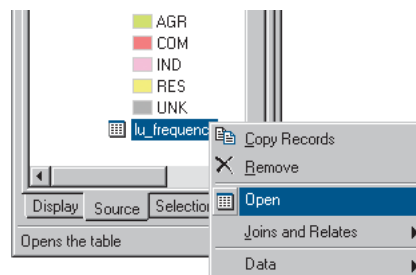

FID*	LAND_USE	Count LAND_USE	Sum Shape Area
1	AGR	141	85240001.453282
2	COM	15	12319720.787529
3	IND	8	32894586.604711
4	RES	257	10426408.594982
5	UNK	40	3130945.053503

2. Close the table window.

## Making a graph

Next you'll create a column graph showing the number of parcels of each land use type.

1. Click the Tools menu, point to Graphs, and click Create. The Graph Wizard appears.

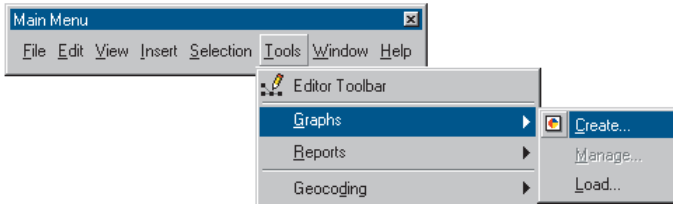

2. On the Graph Wizard dialog box, click the Column graph and click Next.

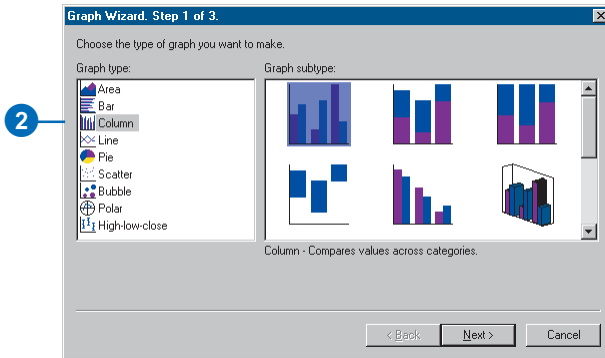

3. Click lu\_frequency as the table containing the data to graph.
4. Make sure that Use selected set of features or records is not checked.
5. Check the field Count\_LAND\_USE as the field to graph.

6. Click Graph data series using Records and click Next.

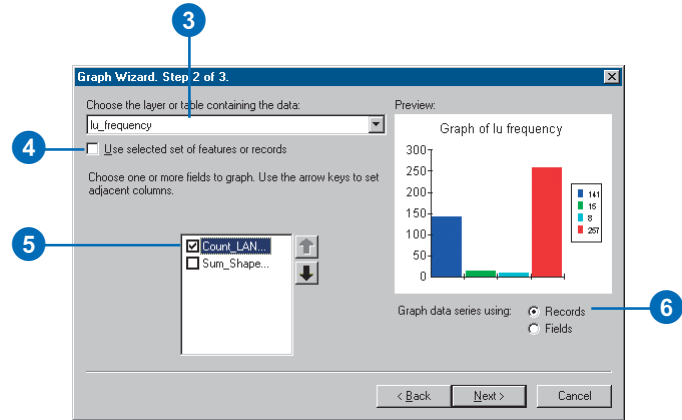

7. Type "Land Use in Noise Contour" as the title.
8. Check Label X Axis With and click LAND\_USE as the labeling field.
9. Uncheck Show Legend.
10. Check Show Graph on Layout and click Finish.

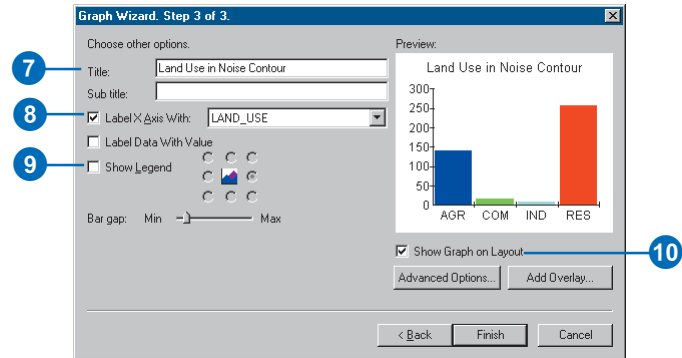

The graph appears on the layout. You can see that most of the parcels are residential.

11. Click the Select Elements tool on the Tools toolbar.

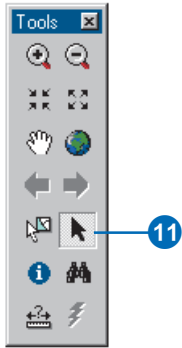

12. Click and drag the graph to the left of the parcel map.

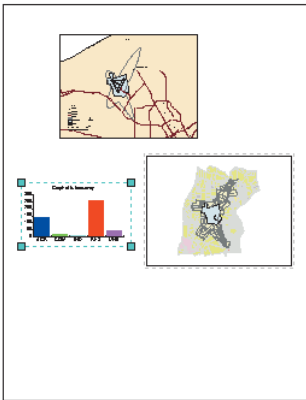

13. With the graph still selected, hold down the Shift key and click the land use map so both are selected.

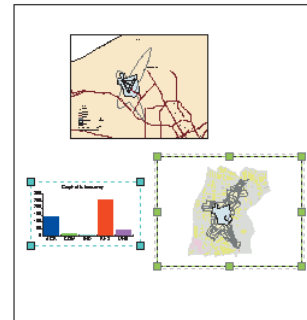

14. Click the Drawing dropdown arrow on the Draw toolbar, point to Align, and click Align Bottom to line up the graph and map.

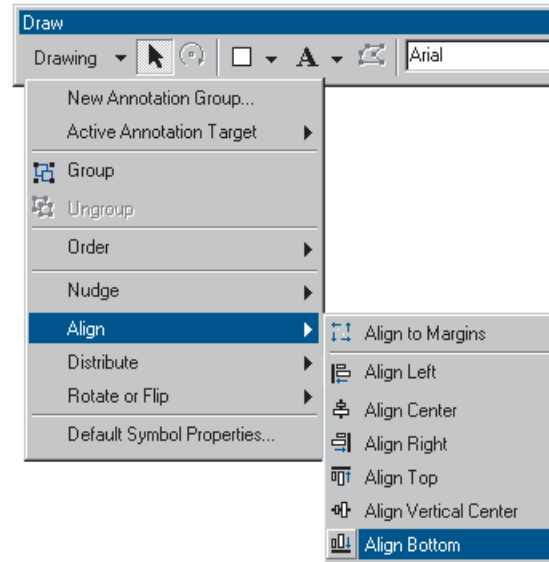

You can stop here or continue with the next exercise. Save your work by clicking Save on the File menu.

## Exercise 3: Working with tables

In this exercise, you'll map population density for the county. A population density map shows where people are concentrated. First, you'll add population data for each census tract. Then you'll calculate population density for each tract and map it.

If necessary, start ArcMap, navigate to the folder where you saved the map from Exercise 2 (airport\_ex), and open the map.

### Creating a new data frame

As with the land use map, you'll start by creating a new data frame to display the data.

1. Switch to layout view, if necessary (click View and click Layout View).
2. Click Insert and click Data Frame.

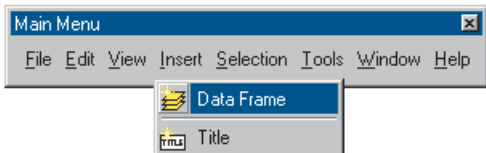

3. In the table of contents, right-click New Data Frame 2 and click Properties.

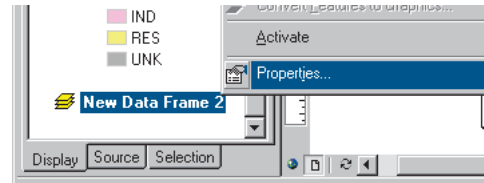

4. Click the General tab and type "Population Density" in the Name text box.
5. Click the Size and Position tab.

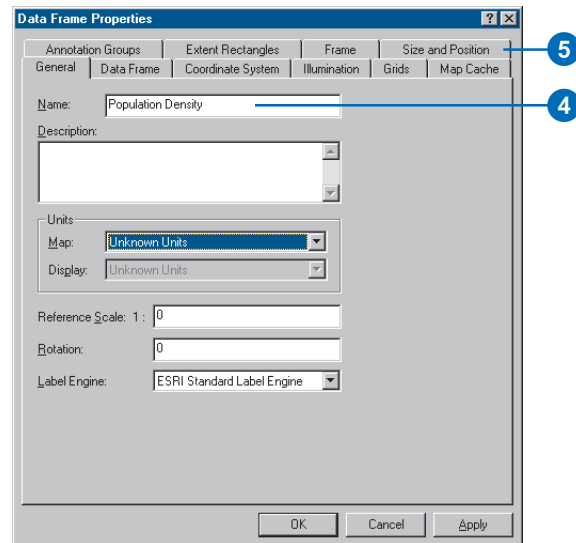



- Set the X position to 9 and the Y position to 2.5.
- Click OK.

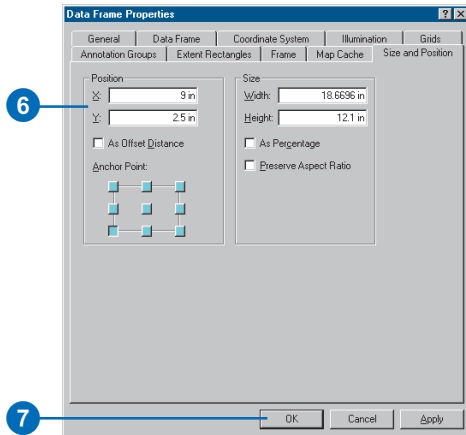

- Hold down the Shift key and click the middle data frame (Land Use) on the page so both frames are selected.
- Click Drawing on the Draw toolbar, point to Distribute, and click Make Same Size.

The data frames are now the same size.

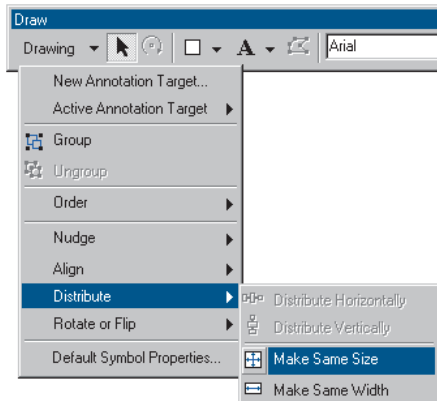

- Click the Population Density data frame on the page so it is the only one selected.

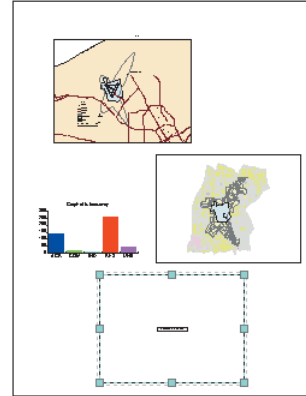

## Adding data from ArcCatalog

You'll add the layers you need by dragging them from ArcCatalog™.

- Start ArcCatalog by clicking the ArcCatalog button on the Standard toolbar in ArcMap. Position the ArcCatalog and ArcMap windows so ArcMap is visible behind the ArcCatalog window.



- In ArcCatalog, navigate to the Map folder on the local drive where you installed the tutorial data (the default installation path is C:\ArcGIS\ArcTutor\Map).
- Click the plus sign next to the Map folder to list the contents.
- Click the airport geodatabase icon to display the contents in the right panel.
- In the right panel, click arterials.

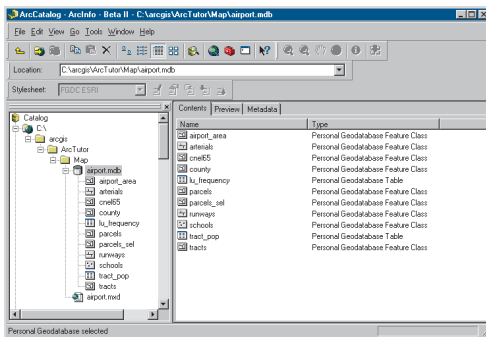

- Hold down the Ctrl key and click tracts and airport\_area to select them as well. The layers are highlighted as you select them.

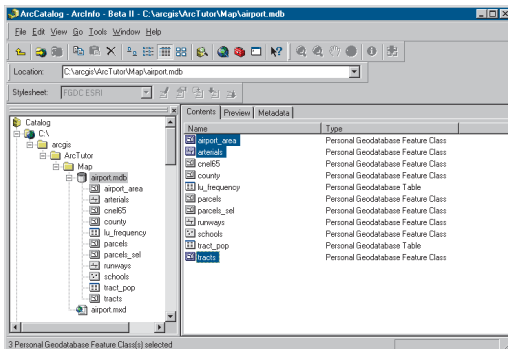

- Point to arterials, hold down the left mouse button, and drag the pointer over the ArcMap layout view (anywhere is fine).

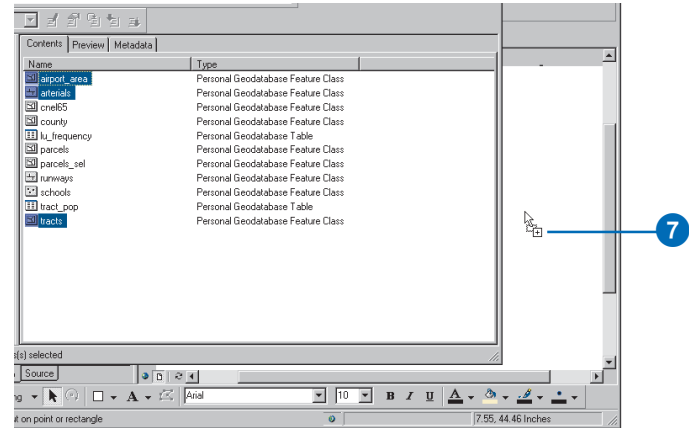

- Release the mouse button. All three layers are added to the new data frame.
- Close ArcCatalog.
- Click tracts in the ArcMap table of contents so only it is selected. Right-click tracts and click Zoom To Layer. The map redraws to show all the tracts and centers them in the data frame.

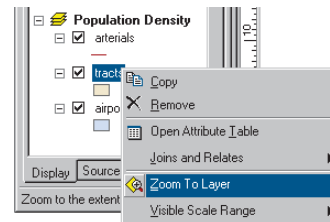

- Right-click the Population Density data frame in the table of contents and click Properties.
- Click the General tab, click the Display dropdown arrow, and set the display units to Feet. You can't change the map units because they are based on the data frame's coordinate system. Click OK.

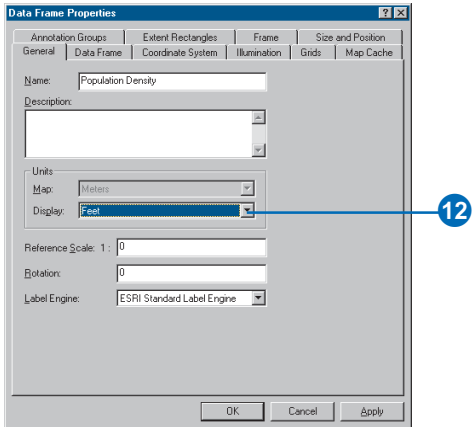

## Adding tabular data

You also need to add the table containing the population data to your data frame.

- In ArcMap, click the Add Data button.



- Navigate to the Map folder on the local drive where you installed the tutorial data (the default installation path is

C:\ArcGIS\ArcTutor\Map) and double-click the airport geodatabase.

- Click tract\_pop (the icon looks like a table).

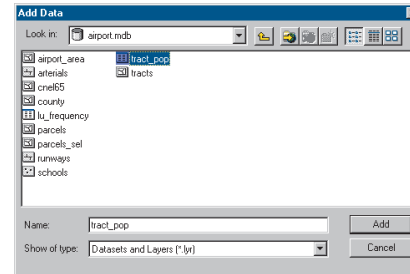

- Click Add. The table is added to the Population Density data frame in the table of contents. ArcMap activates the Source tab so you can access the table.

## Joining tables

The next step is to join the table containing the population data to the census tract data table. You'll do this using the census tract ID as the common field.

- Right-click tracts in the table of contents and click Open Attribute Table to see the existing attributes including the census tract ID.

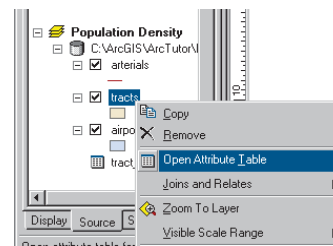

Attributes of tracts					
FID	Shape	Shape_Length	Shape_Area	TRACT_ID	
1	Polygon	23359.0646179392	29501864.0718	100	100
2	Polygon	20350.8213216268	17906796.4727	200	200
3	Polygon	19764.5068628924	17038547.9629	300	300
4	Polygon	71734.650763681	182638877.306	400	400
5	Polygon	41535.3888513427	101159098.343	500	500
6	Polygon	61452.6622484381	183391558.187	600	600
7	Polygon	91262.7436119726	292795476.836	700	700
8	Polygon	18980.4140028922	17437646.7340	801	801
9	Polygon	108657.097454915	452483831.055	802	802

Now right-click `tract_pop` in the table of contents and click `Open`. The table contains the `TRACT_ID` field and the population of each tract.

Close the tables before proceeding with the join.

Attributes of tract_pop		
Rowid*	TRACT_ID	POPULATION
1	100	4231
2	200	1683
3	300	2580
4	400	6012
5	500	7046
6	600	5170
7	700	6203
8	801	2914
9	802	3295

- Right-click `tracts` in the table of contents again, point to `Joins and Relates`, and click `Join`.

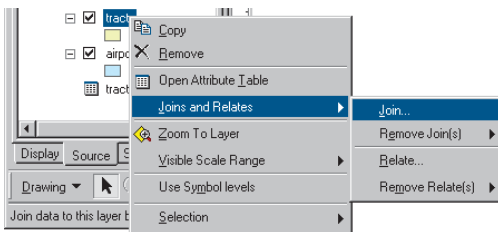

- Click the dropdown arrow in the first text box and click `Join attributes from a table`.
- Click the dropdown arrow in the next text box, scroll down, and click `TRACT_ID` as the field in the layer to base the join on.

- Click the dropdown arrow in the next text box and click `tract_pop` as the table to join to the layer.
- In the next text box, click `TRACT_ID` as the field in the table to base the join on.
- Click `OK` to join the table to the layer. Click `Yes` if you are prompted to create an index.

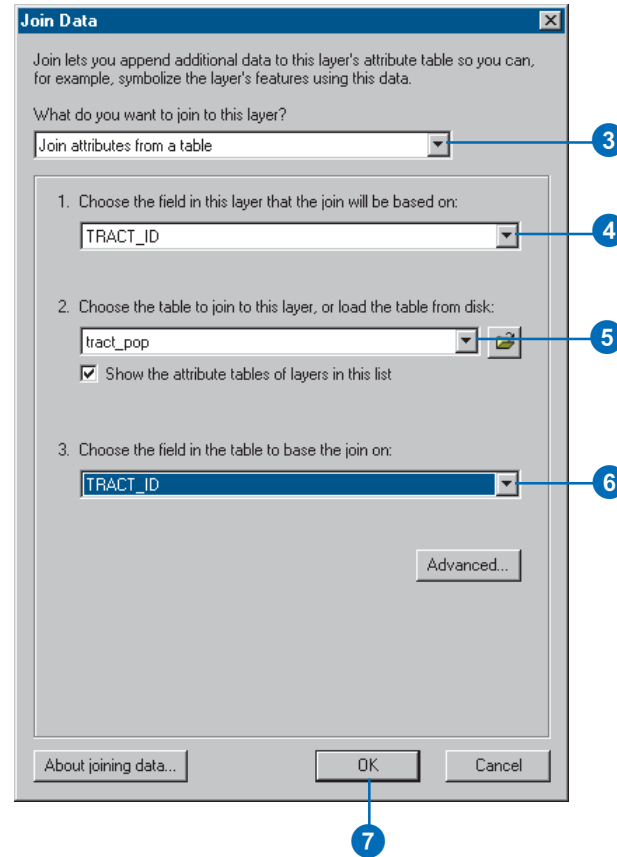

- Right-click tracts and click Open Attribute Table. The population value has been added to each tract.

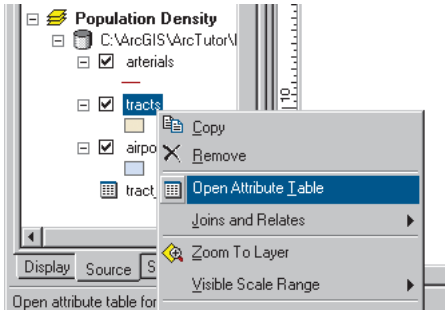

FID	Shape	Shape_Length	Shape_Area	tracts.TRACT_ID	Rowid	tract_pop.TRACT_ID	tract_pop.POPULATION
1	Polygon	23359.064618	29501864.07187100	1	100	100	4231
2	Polygon	20350.821322	17906796.47279200	2	200	200	1683
3	Polygon	19764.508863	17038547.96297300	3	300	300	2580
4	Polygon	71734.650764	182638877.30674000	4	400	400	6012
5	Polygon	41535.389851	101159098.34315000	5	500	500	7046
6	Polygon	61452.862248	183391958.18776000	6	600	600	5170
7	Polygon	91262.743612	292795476.83697000	7	700	700	6203
8	Polygon	18980.414003	17437646.73404801	8	801	801	2914
9	Polygon	108657.097495	452483831.09578002	9	802	802	3296
10	Polygon	182284.761421	982326195.00319000	10	900	900	3059
11	Polygon	124503.435050	510338863.63831000	11	1000	1000	1364
12	Polygon	161714.527502	1171289698.14211000	12	1100	1100	1868
13	Polygon	168383.265964	1277251210.40012000	13	1200	1200	3070
14	Polygon	173305.569710	1271243904.09613000	14	1300	1300	5442
15	Polygon	110685.412067	563971341.48881400	15	1400	1400	2945
16	Polygon	200138.818819	1454467245.02415000	16	1500	1500	3436
17	Polygon	161157.789413	1019489405.54716000	17	1600	1600	2305
18	Polygon	156142.837956	880895065.89381700	18	1700	1700	3378

## Adding a field to an attribute table

To map population density, you'll need to add a new field to the tracts layer. You'll use this field to store the population density of each tract.

- Click the Options button at the bottom of the Attributes of tracts window and click Add Field.

If a message appears indicating the table is in use by another user, make sure you closed ArcCatalog.

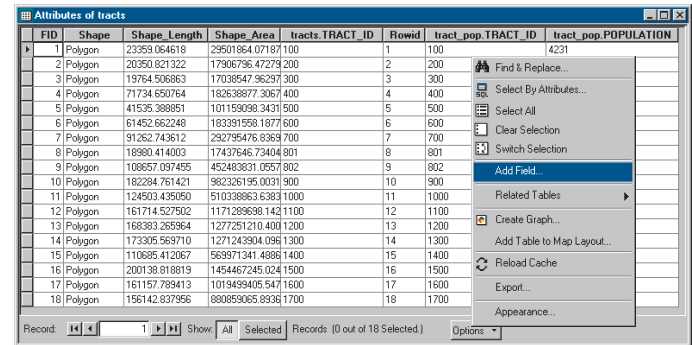

- In the Add Field dialog box, type "POP\_DEN" as the field name.
- Click the Type dropdown arrow and click Long Integer.
- Click OK.

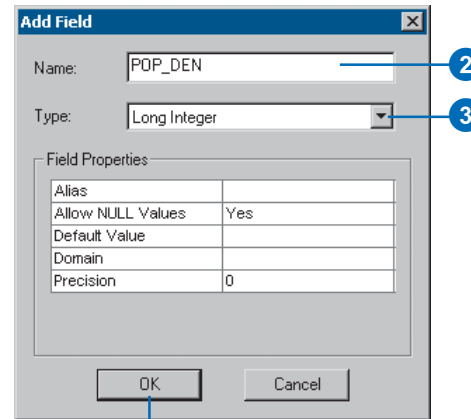

You should see the new field added to the attribute table. The field name you entered will be concatenated with tracts, to appear as tracts.POP\_DEN.

## Calculating attribute values

You'll calculate the population density for each tract by dividing the population by the area of each tract; this will give you the number of people per square mile. To do this, you'll use the editing functions of ArcMap to edit the census tract attributes. You can make calculations without being in an editing session; however, in that case, there is no way to undo the results. (In Exercise 4, you'll edit the geometry of a feature.)

1. Click the Editor Toolbar button on the Standard toolbar. The Editor toolbar appears.

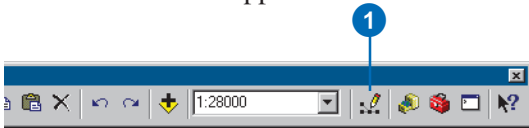

2. Click Editor and click Start Editing.



3. Right-click tracts.POP\_DEN and click Calculate Values. The Field Calculator appears.

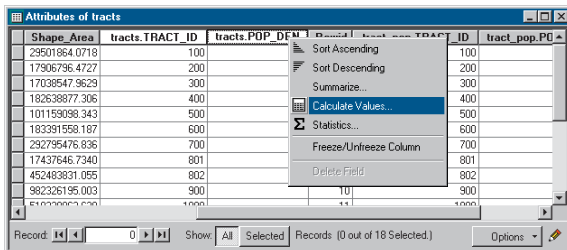

The first part of the formula is entered for you: tracts.POP\_DEN = . The full formula will look like this: tracts.POP\_DEN = [tracts\_pop.POPULATION] / ([tracts.Shape\_Area] / 27878400).

Dividing the area by 27,878,400 converts the area of each tract, stored in square feet, to square miles. You can type the formula right into the box or use the buttons on the dialog box. In this exercise, you'll use both.

4. Click tracts\_pop.POPULATION in the Fields list.
5. Click the division symbol.
6. Type a space and a left parenthesis from the keyboard.
7. Click tracts.Shape\_Area from the field list.
8. Click the division symbol.
9. Type a space and type "27878400".
10. Type a space and a right parenthesis from the keyboard.
11. Click OK.

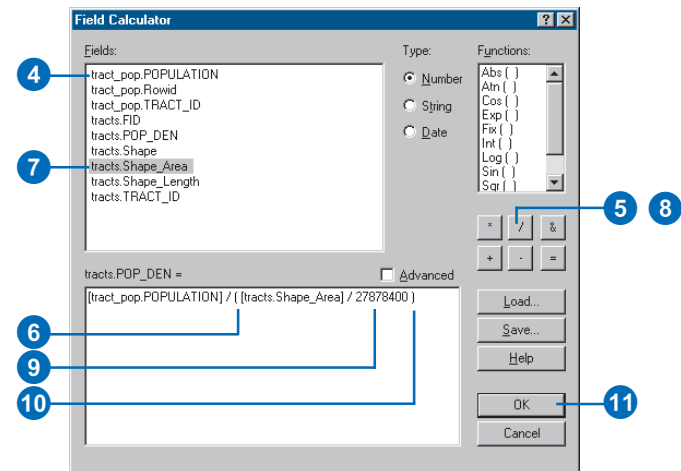

When the dialog box closes, you can see the population density values for each tract in people per square mile in the table.

FID	Shape	Shape_Length	Shape_Area	tracts.TRACT_ID	tracts.POP_DEN	tr
1	Polygon	23359.064618	29501864.07187	100	3998	1
2	Polygon	20350.821322	17906796.47279	200	2620	2
3	Polygon	19764.506863	17038547.96297	300	4221	3
4	Polygon	71734.650764	182638877.3067	400	918	4
5	Polygon	41535.388851	101159098.3431	500	1942	5
6	Polygon	61452.662248	183391558.1877	600	786	6
7	Polygon	91262.743612	292795476.8369	700	591	7
8	Polygon	18980.414003	17437646.73404	801	4659	8
9	Polygon	108657.097455	452483831.0557	802	203	9
10	Polygon	182284.761421	982326195.0031	900	87	10
11	Polygon	124503.435050	510338863.6383	1000	75	11
12	Polygon	161714.527502	1171289698.142	1100	44	12
13	Polygon	168383.265964	1277251210.400	1200	67	13
14	Polygon	173305.569710	1271243904.096	1300	119	14
15	Polygon	110685.412067	569371341.4886	1400	144	15
16	Polygon	200138.818819	1454467245.024	1500	67	16
17	Polygon	161157.789413	1019499405.547	1600	63	17
18	Polygon	156142.837956	880859065.8936	1700	107	18

12. Click the Editor menu on the Editor toolbar and click Stop Editing.



13. Click Yes when prompted to save your edits.

14. Close the Editor toolbar and close the attribute table.

For more information on adding and calculating attributes, see Chapter 10, 'Working with tables'.

## Classifying features by quantity

You can now map the tracts based on their population density values to see where people are concentrated in relation to the airport and to major roads.

1. Right-click tracts in the table of contents and click Properties.

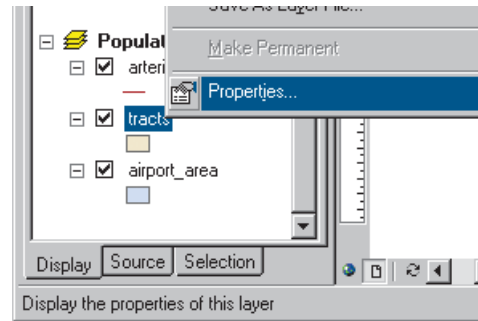

2. Click the Symbology tab. All tracts are currently drawn using the same symbol (the same solid fill color).

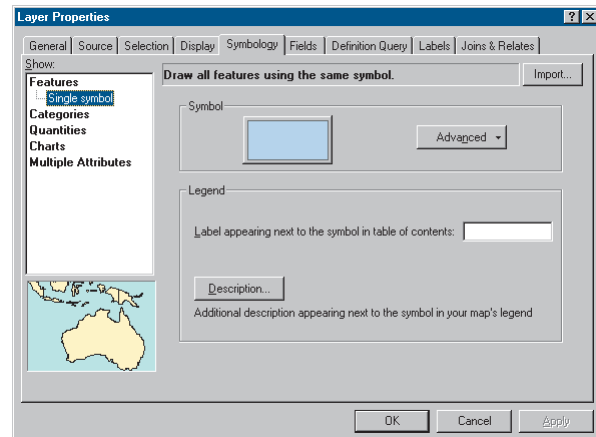

3. Click Quantities in the Show box. Graduated colors is automatically highlighted.
4. Click the Value dropdown arrow and click tracts.POP\_DEN as the field to use to shade the tracts.
5. Click the Color Ramp dropdown arrow and click the blue color ramp.

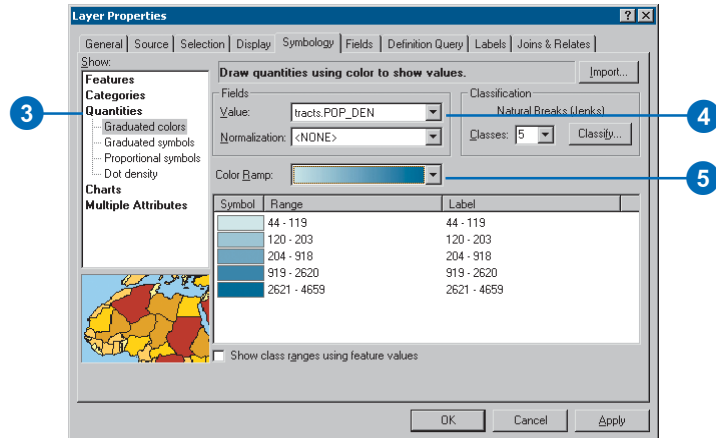

ArcMap chooses a classification scheme and the number of classes for you. You can modify these by clicking the Classify button in the Layer Properties dialog box. For now, just use the default classification.

6. Click OK.
7. Click the Display tab at the bottom of the table of contents.

8. Arterials should be at the top of the layers list. If not, click arterials in the table of contents and drag it to the top of the layers list in the Population Density data frame. Click airport\_area and drag it so it is just below arterials. Now these layers draw on top of the tracts.

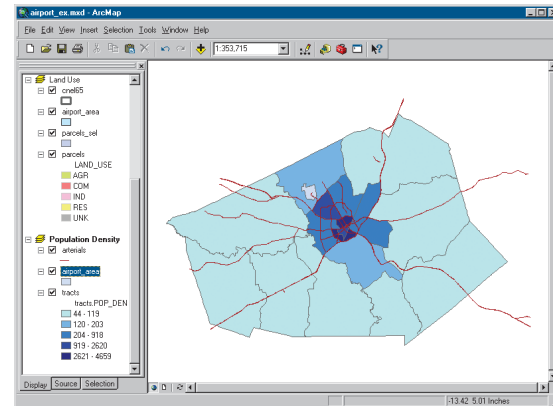

9. Switch to data view to get a closer look at the tracts. Click View and click Data View.

For more on classifying and displaying data, see Chapter 6, 'Symbolizing features'.

You've now completed Exercise 3. You can continue with the next exercise or continue at a later time. Be sure to save your work by clicking Save on the File menu.



## Exercise 4: Editing features

You can use ArcMap to edit your data as well as create maps. In this exercise you'll extend the airport road to create a new loop road joining an existing arterial road. This exercise is a brief introduction to editing, which is covered in more detail in *Editing in ArcMap*.

If necessary, start ArcMap, navigate to the folder where you saved the map from Exercise 3 (airport\_ex), and open the map.

### Exporting data

You'll be working with the Schools data frame. First, make a copy of the arterials data. That way, in case you need to, you can start over again with the original data.

1. Switch to data view by clicking the View menu and clicking Data View, if necessary.
2. Right-click the Schools data frame in the table of contents and click Activate.

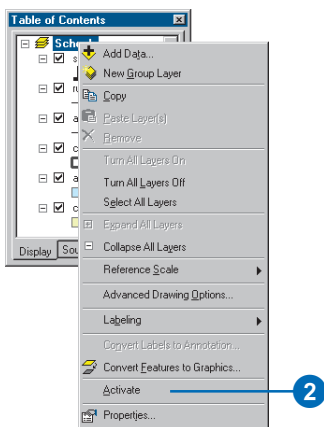

3. Right-click arterials, point to Data, and click Export Data.

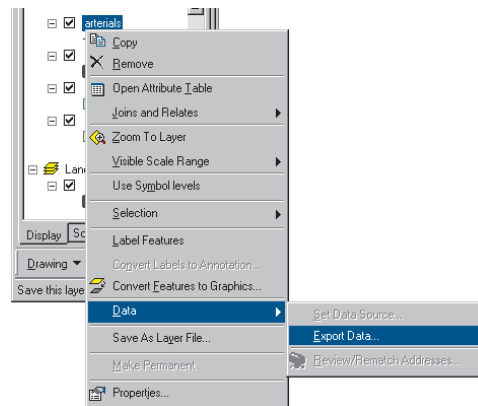

4. Click the Export dropdown arrow and click All features.
5. Click Use the same Coordinate System as this layer's source data.
6. Save the new feature class as arterials\_new in the airport geodatabase (the default installation path is C:\ArcGIS\ArcTutor\Map\airport.mdb).

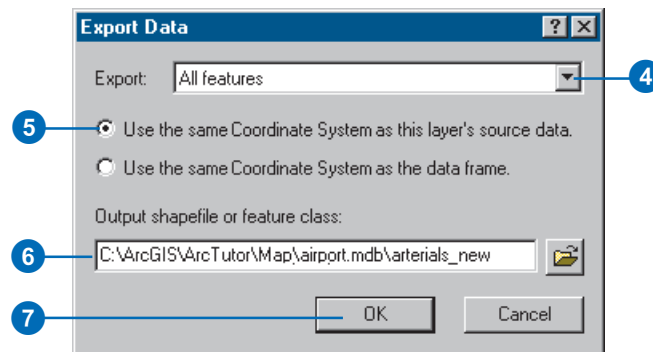

- Click OK to export the data.
- Click Yes when prompted to add the layer to the map.

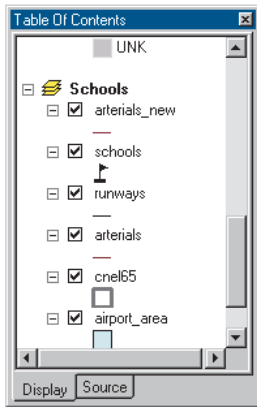

Using Export makes a copy of the data itself. If you'd chosen Copy from the menu, you'd be copying the layer, which is only a pointer to the underlying data and information about how the data is displayed.

## Creating a new feature

You edit features in ArcMap using the Editor toolbar. All the layers in a workspace are available for editing within the same editing session. You specify which layer (the "target") new features will be added to.

- Click the Zoom In button on the Tools toolbar and zoom in to the area around the existing road and the road you're adding.

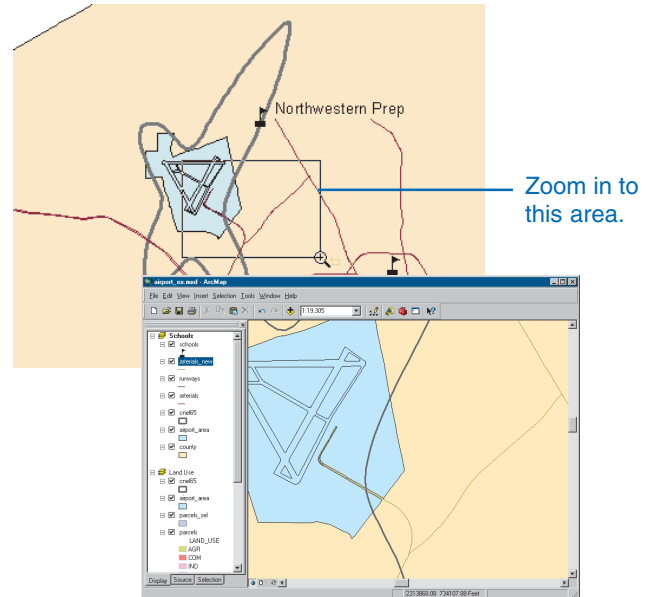

- Turn off the cnel65 and airport\_area layers by unchecking the boxes next to them in the table of contents so you can more easily see the existing roads.

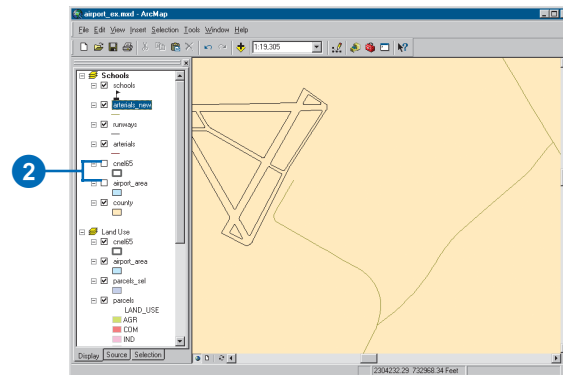

- Click the Editor Toolbar button to display the Editor toolbar.

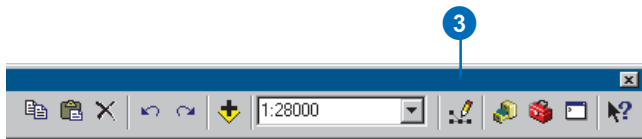

- Click the Editor menu and click Start Editing.



## Setting snapping

Snapping lets you specify that new features connect to or align with existing features.

- Click Editor and click Snapping.



- Check the boxes for Edge and End for `arterials_new`. This specifies that the new line you draw in the `arterials_new` dataset will snap to existing lines (edges) and endpoints of existing lines.

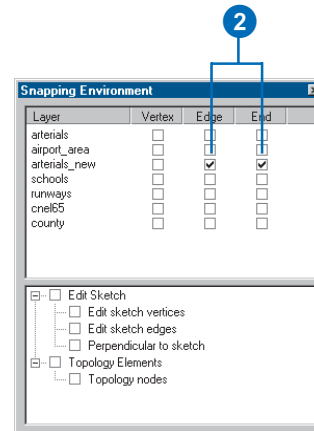

- Close the Snapping Environment dialog box.

## Digitizing a feature

- Click the Target dropdown arrow and click `arterials_new` as the feature class you want to create new features in.
- Click the Sketch tool on the Editor toolbar.



- The pointer changes to a crosshair with a circle. Move the mouse pointer over the end of the existing road—the circle snaps to the end.

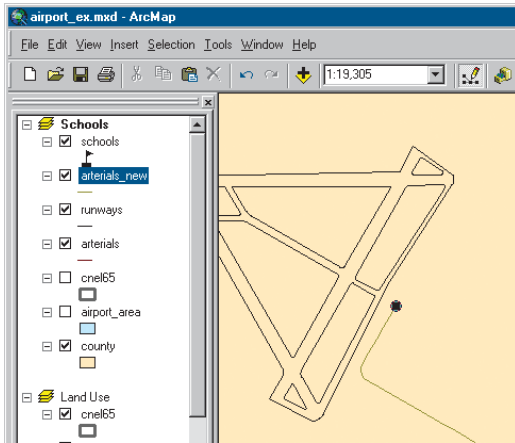

4. Click to start the new road.

5. Move the mouse pointer back over the existing road and right-click to display the context menu.

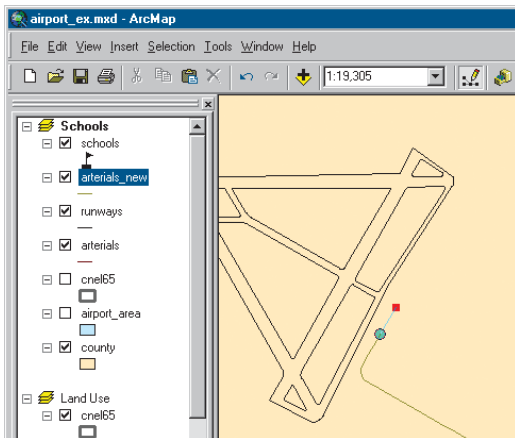

6. Click Parallel.

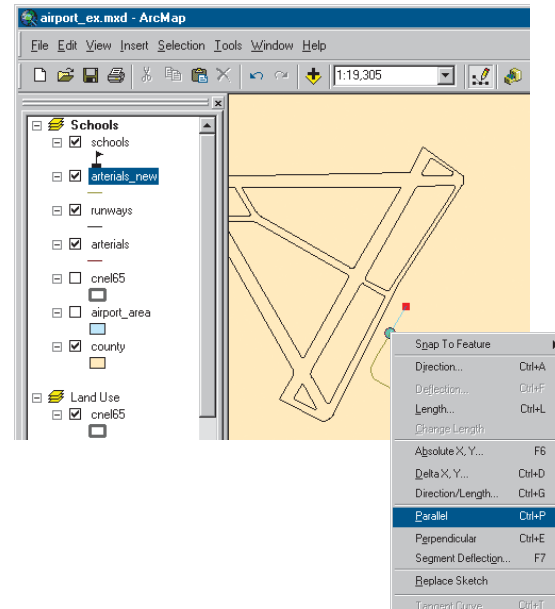

7. Move the mouse pointer in the direction you want the new road to go (up and to the right). Right-click and click Length.

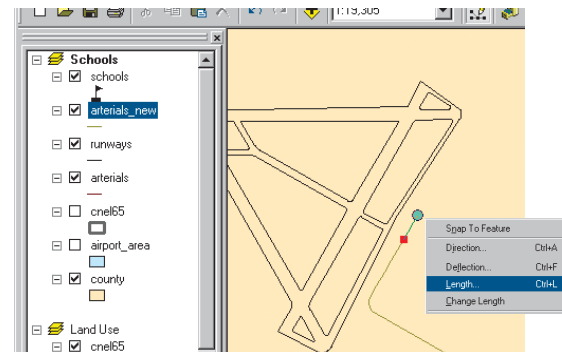

8. Type “900” (map units) and press Enter. ArcMap places a vertex at the correct location.

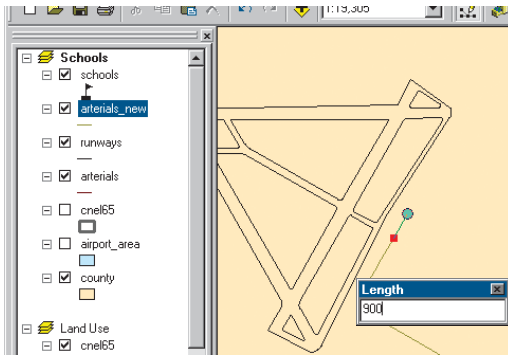

9. Right-click again and click Tangent Curve.

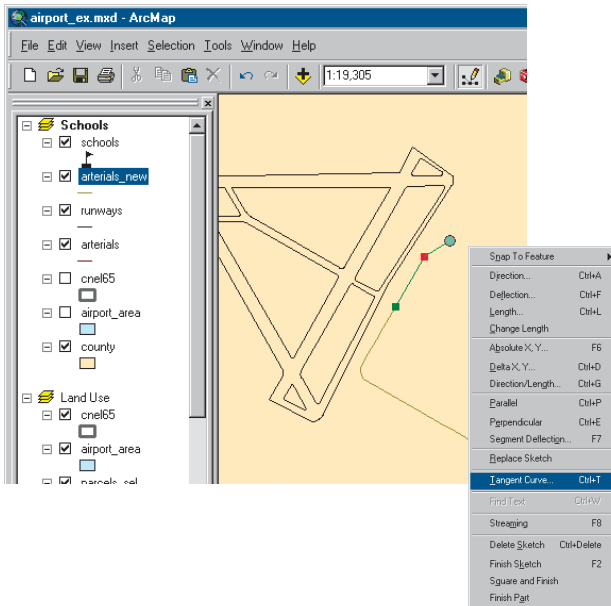

10. Click the dropdown arrow in the upper box and click Arc Length. Click the box to the right and type a length of “400”. In the lower box, click the dropdown arrow and click Delta Angle. Click the box to the right and type “90” (degrees). Click the button next to Right, if necessary. Then press Enter.

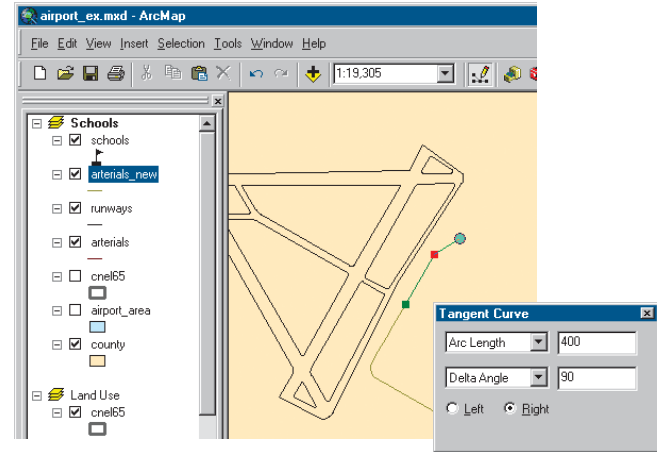

ArcMap draws the curve.

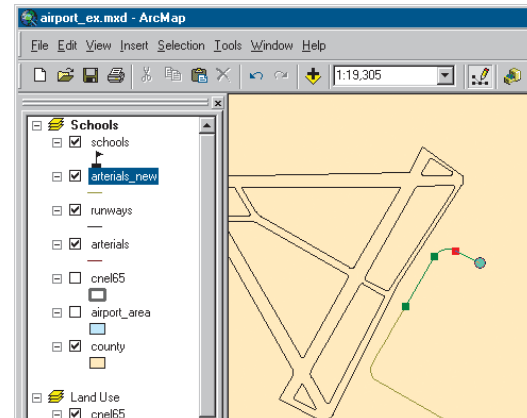

11. Move the mouse pointer so it snaps to the existing road, but don't click the mouse. You want the next segment of the new road to be parallel to the existing road.

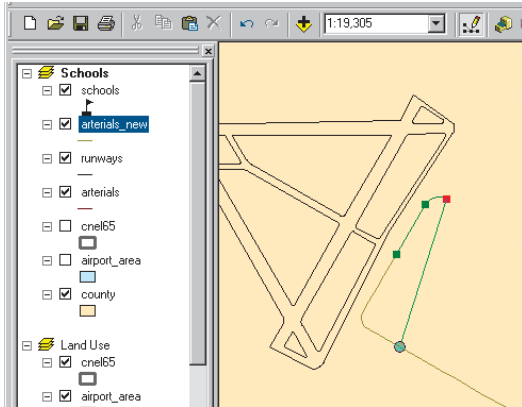

12. Right-click and click Parallel. The line is constrained to be parallel to the existing road.

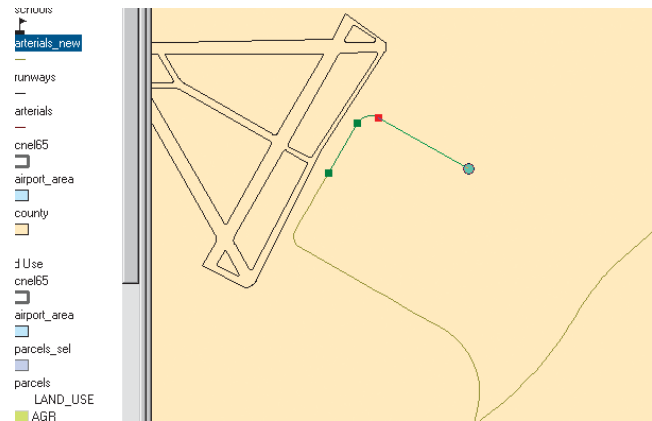
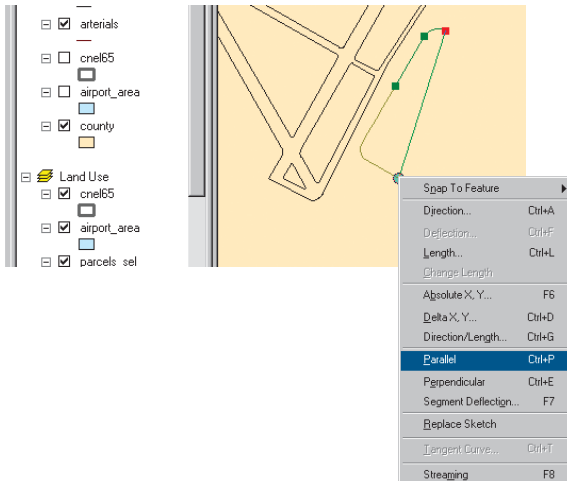

13. To finish the road, move the mouse pointer over the road that you want the new road to intersect, and make sure the circle snaps to it. Double-click to end the line.

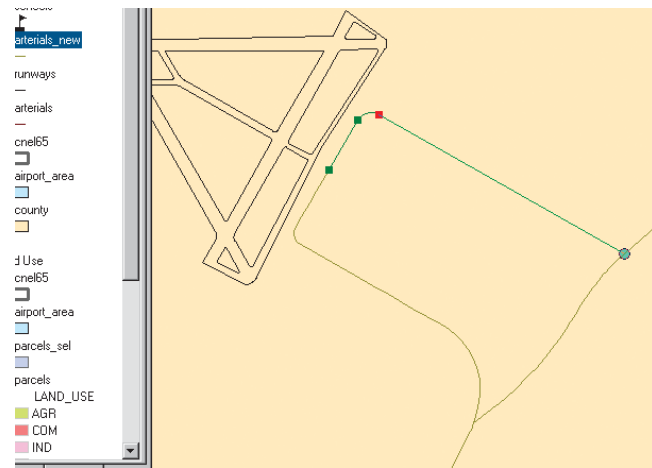

The new road is highlighted in a thick blue line.

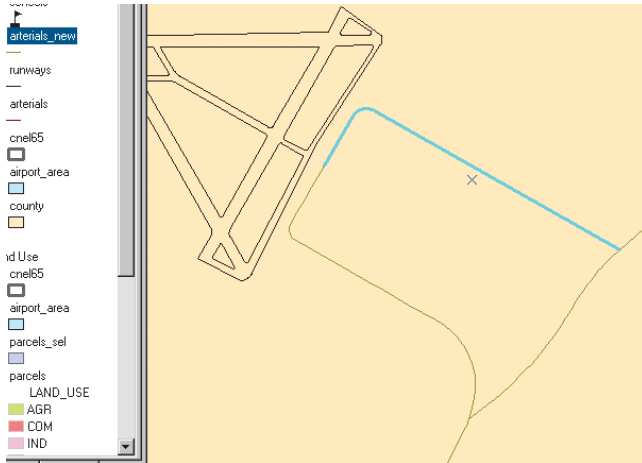

### Adding attributes to new features

You can also add the name of the new road.

1. Click the Attributes button on the Editor toolbar.



2. Click next to NAME on the list of attributes, type "AIRPORT DR", and press Enter.

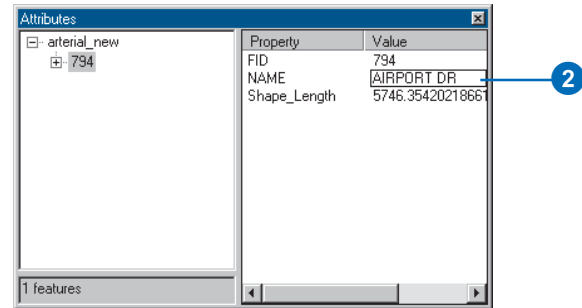

3. Close the Attributes window.
4. Click the Editor menu and click Stop Editing. Click Yes when prompted to save your edits.

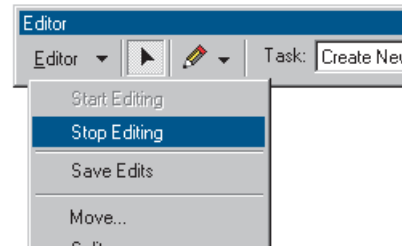

5. Close the Editor toolbar.

- Right-click `arterials_new` in the table of contents and click `Label Features`. The road you added is labeled with its name.

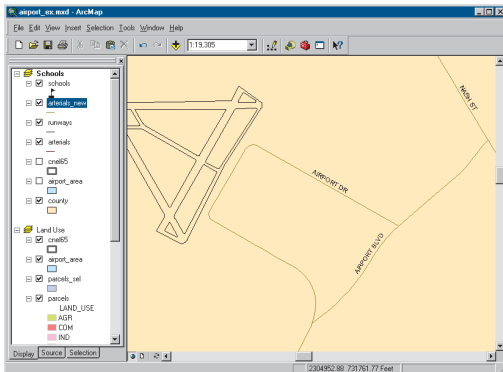
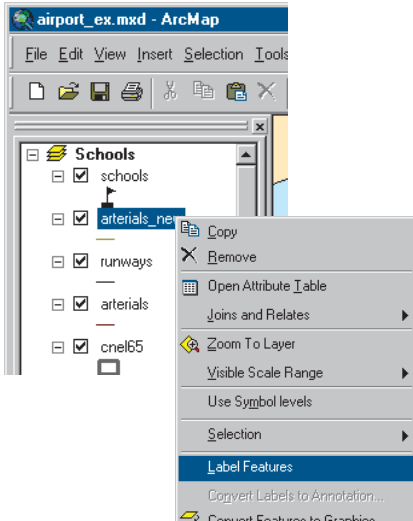

- Turn the `cnel65` and `airport_area` layers back on by checking their boxes in the table of contents.

- Switch to layout view by clicking the View menu and clicking `Layout View`. You can see that the road has been added to your map.
- You zoomed in for editing (when you switched to data view), so type “1:100,000” in the Map Scale text box on the Standard toolbar and press `Enter` to set the map scale.



Use the Pan tool on the Tools toolbar to place the noise contour in the center of the map.

You can continue with the final exercise or stop here. If you stop, be sure to save your work by clicking `Save` on the File menu.



## Exercise 5: Working with map elements

In this exercise, you'll add additional map elements to complete your poster and print it.

If necessary, start ArcMap, navigate to the folder where you saved the map from Exercise 4 (airport\_ex), and open the map.

### Adding a background, titles, legends, and scalebars

1. Switch to layout view by clicking the View menu and clicking Layout View, if necessary.
2. Click the Land Use data frame on the page so it's highlighted. In the table of contents, uncheck the parcels\_sel layer so it's not displayed (that way, the map will show the land use types within the noise contour).

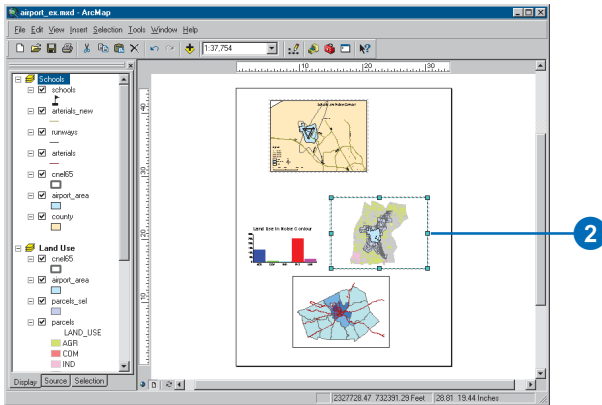

3. Right-click the data frame and click Properties.

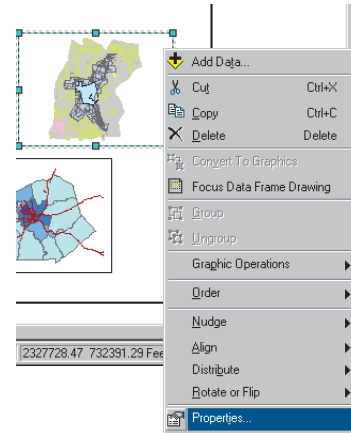

4. Click the Frame tab. Click the Background dropdown arrow and click Sand. Click OK.

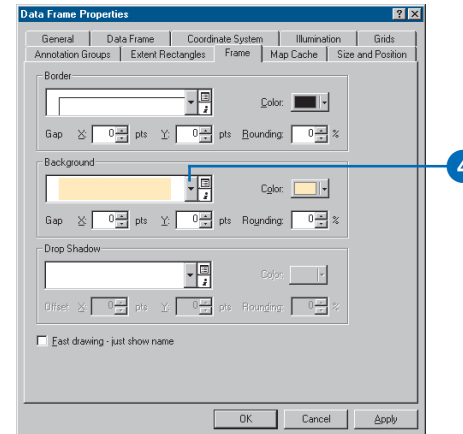

5. Click Insert and click Title.

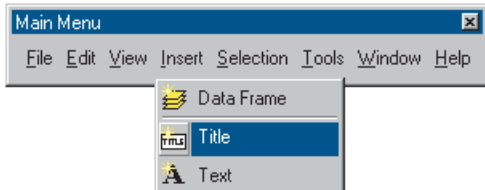

6. Type “Land Use within Noise Contour” in the text box and press Enter.

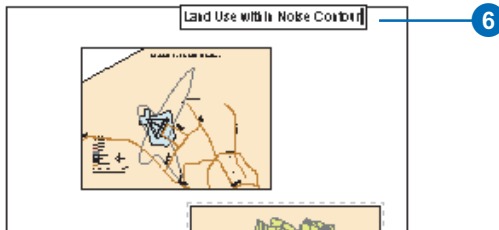

7. Click the Text Size dropdown arrow on the Draw toolbar. Click 36 to make the title 36 point.

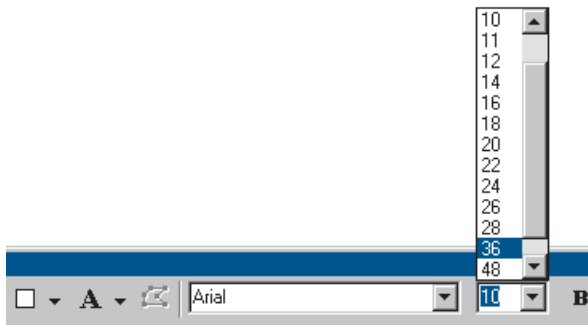

8. Drag the title onto the Land Use data frame, as shown below.

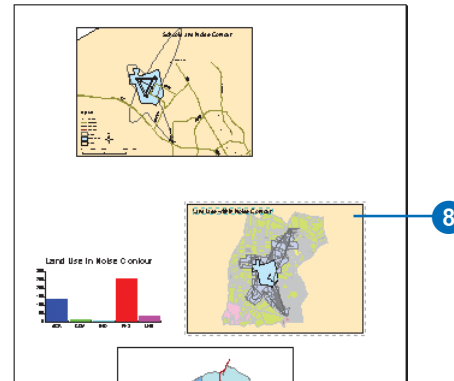

9. Click Insert and click Legend.

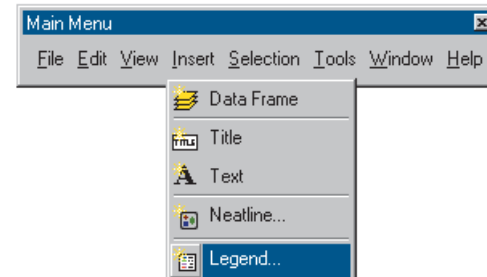

The Legend Wizard appears.

10. Click Next several times to step through the wizard, accepting the default legend parameters. Click Finish when you're done.

- Drag the legend to the lower-left corner of the data frame, as shown below. Make it smaller by clicking the upper-right handle and dragging it down and to the left.

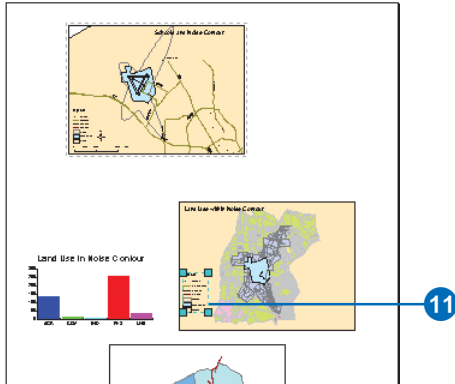

- Click Insert and click Scale Bar.

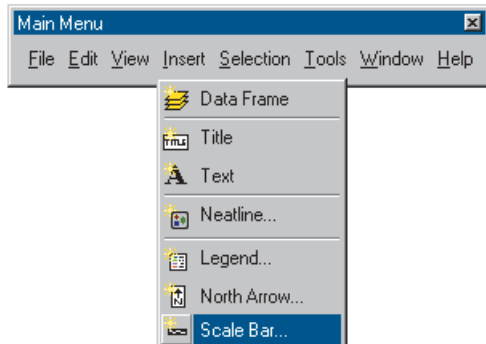

- Click Scale Line 1 and click OK. Drag the scalebar under the legend and make it smaller.

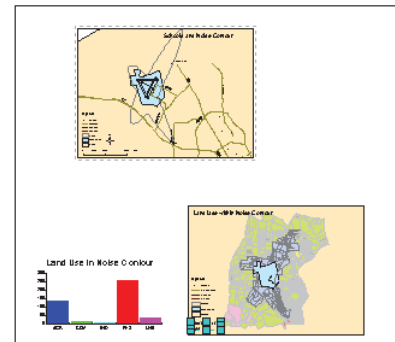
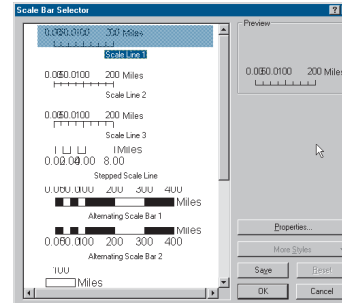

- Now do the same for the Population Density data frame. First click to select it. Set the background to Sand, make the title read "Population Density", and add a legend and scalebar. Place the legend in the upper-left corner of the data frame and place the scalebar in the lower-left corner.
- Click the Schools data frame to select it and set the background to Olive.
- You only need one North arrow since all maps are oriented in the same direction. Click the North arrow in the Schools data frame and enlarge it by dragging the upper-right handle. Then drag the North arrow to the lower-right corner of the page.

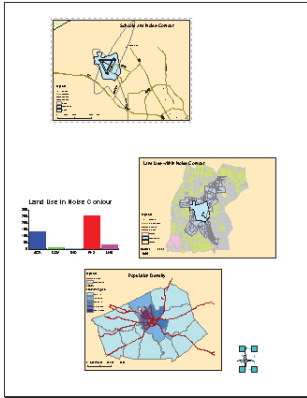

- Click the New Text tool on the Draw toolbar and click the top of the page. Type “Proposed Airport Expansion” as the title and press Enter. Set the size to 72 point and make the title bold by clicking the Bold button. Position the title at the top and center of the page.

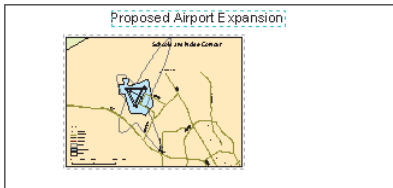

### Adding drop shadows

You can add drop shadows to most of the graphic elements on the layout page. Add a drop shadow to each data frame.

- Click the Population Density data frame to activate it.
- Right-click the Population Density data frame and click Properties.

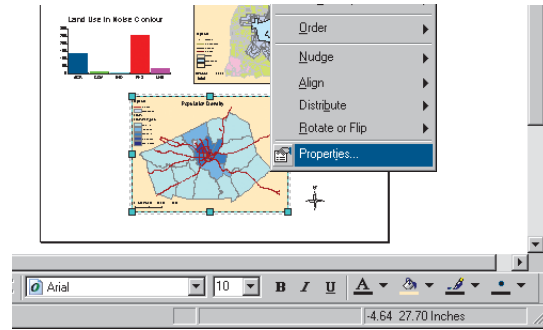

- Click the Frame tab.
- Click the Drop Shadow dropdown arrow and click Gray 30%.
- Type “50” for the X Offset and “-50” for the Y Offset.
- Click OK.

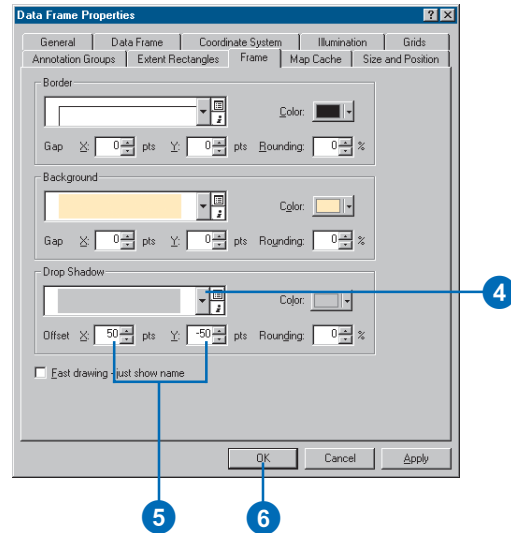

- Repeat the steps above to add drop shadows to the Schools and Land Use data frames. When finished, your map should look like this:

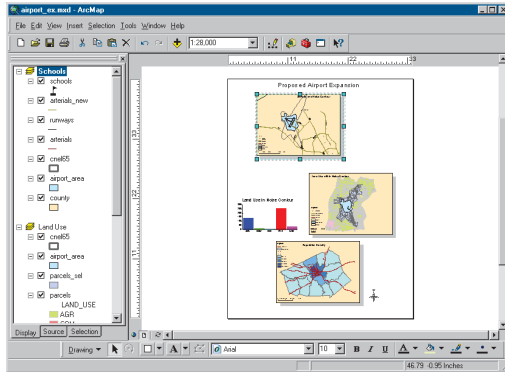

## Adding a neatline

- Click Insert and click Neatline.

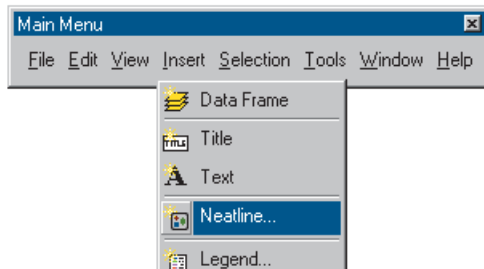

- Click Place inside margins.
- Type in a gap of 36 points. This places the neatline about one-half inch inside the margin of the page.

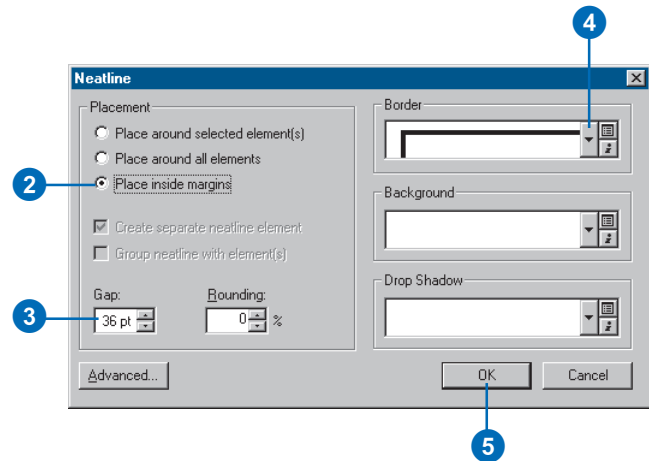

- Click the Border dropdown arrow and click a border size of 3.0 points.
- Click OK. Your map should look like this.

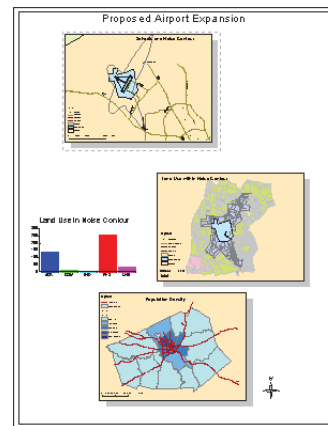

## Printing a map

Your map is finished. You can print it if you have a printer connected to your computer. If your printer doesn't print the full size (34 by 44 inches), you can scale the map down to fit your printer.

1. Click the File menu and click Print.
2. If the map is larger than the printer paper, click Scale Map to fit Printer Paper. (Tile map to printer paper will print the map at full scale on separate sheets of paper so you can paste them together to display the full map.)
3. Click Setup.

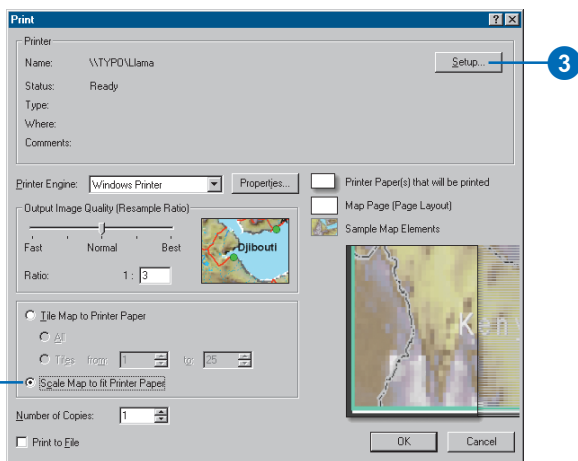

4. Click Portrait for the Paper Orientation.

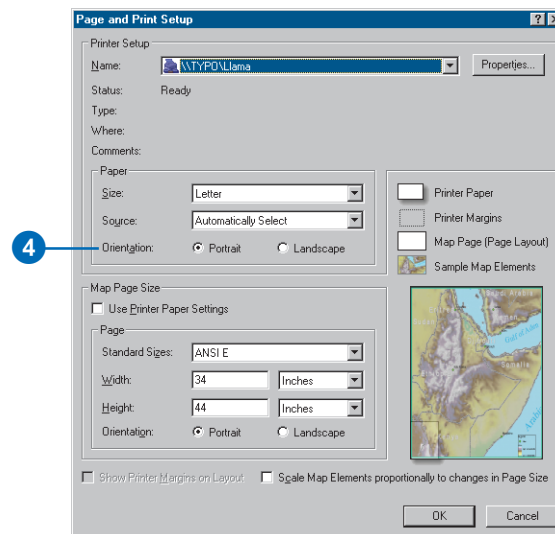

5. Click OK on the Page and Print Setup dialog box, then click OK on the Print dialog box to print the map.

For more information on adding graphics to your map, see Chapter 7, 'Working with graphics and text'. For more on map layout and composition, see Chapter 15, 'Laying out and printing maps'.

In this chapter, you've been introduced to many of the ArcMap tasks you'll often use. The rest of this book provides more detail on these tasks and shows you many more tasks you can perform using ArcMap.