

Cadastral Editor Tutorial for Survey Analyst

IN THIS TUTORIAL

- **Exercise 1: Organizing the tutorial data**
- **Exercise 2: Creating and managing a cadastral fabric**
- **Exercise 3: Creating new parcels in fabric jobs**
- **Exercise 4: Working with parcel construction tools**
- **Exercise 5: Adding control points to your cadastral fabric**
- **Exercise 6: Appending groups of parcels to the cadastral fabric**
- **Exercise 7: Adjusting your cadastral fabric**

The cadastral editor introduces a new set of tools for maintaining land records in ArcGIS Survey Analyst 9.2

In this tutorial, you will be introduced to the cadastral fabric dataset. A cadastral fabric is a seamless parcel boundary network, which is created and maintained using data from survey plans. You will create a cadastral fabric and migrate some existing parcel-based GIS data from Alachua County, Florida, into your cadastral fabric. In the following exercises you will edit the cadastral fabric and add new parcel data from the Timberbrook and Edgewood survey plans.

When adding parcel data from survey plans, you are essentially updating your cadastral fabric (boundary network) with new survey measurements. The Least Squares Adjustment adjusts the cadastral fabric in response to these new measurements and finds a new “best-fit” for all the parcel corners.

Many geographic information systems use cadastral records to build the base map for all other layers in the GIS. As the cadastral fabric is adjusted, overlying GIS layers will fall out of alignment with the parcel base map. In exercise 7, you will run a GIS feature adjustment which applies the coordinate shifts resulting from the Least Squares Adjustment to your overlaying GIS feature classes. The GIS feature adjustment will bring your GIS layers back into alignment with your updated cadastral fabric.

Copyright © 1999–2004 ESRI.

All rights reserved.

Printed in the United States of America.

The information contained in this document is the exclusive property of ESRI. This work is protected under United States copyright law and the copyright laws of the given countries of origin and applicable international laws, treaties, and/or conventions. No part of this work may be reproduced or transmitted in any form or by any means, electronic or mechanical, including photocopying and recording, or by any information storage or retrieval system, except as expressly permitted in writing by ESRI. All requests should be sent to Attention: Contracts Manager, ESRI, 380 New York Street, Redlands, CA 92373-8100, USA.

The information contained in this document is subject to change without notice.

DATA CREDITS

Tutorial data: Courtesy of Alachua County Florida.

The tutorial scenario is fictitious and some of the data has been altered to suit the purposes of the tutorial.

CONTRIBUTING WRITERS

Christine Leslie and Chris Buscaglia

U.S. GOVERNMENT RESTRICTED/LIMITED RIGHTS

Any software, documentation, and/or data delivered hereunder is subject to the terms of the License Agreement. In no event shall the U.S. Government acquire greater than RESTRICTED/LIMITED RIGHTS. At a minimum, use, duplication, or disclosure by the U.S. Government is subject to restrictions as set forth in FAR §52.227-14 Alternates I, II, and III (JUN 1987); FAR §52.227-19 (JUN 1987) and/or FAR §12.211/12.212 (Commercial Technical Data/Computer Software); and DFARS §252.227-7015 (NOV 1995) (Technical Data) and/or DFARS §227.7202 (Computer Software), as applicable. Contractor/Manufacturer is ESRI, 380 New York Street, Redlands, CA 92373-8100, USA.

ESRI, ArcView, SDE, and the ESRI globe logo, ArcInfo, ArcSDE, ArcCatalog, ArcMap, ArcToolbox, ArcStorm, ArcEditor, ArcGIS, ArcObjects, StreetMap, the ESRI Press logo, and GIS by ESRI, and www.esri.com are trademarks, registered trademarks, or service marks of ESRI in the United States, the European Community, or certain other jurisdictions.

The names of other companies and products herein are trademarks or registered trademarks of their respective trademark owners.

Exercise 1: Organizing the tutorial data

To work with this tutorial, you will need to have the ArcGIS Survey Analyst extension installed. Before you can begin the tutorial, you must find and organize the data you will be working with. Using ArcCatalog, browse for and create a new folder connection to your data:

1. Click the start menu, point to Programs, point to ArcGIS and click ArcCatalog.
2. Navigate to the location of the tutorial (the default path is \arcgis\ArcTutor on the drive where you have ArcGIS installed).
3. Select the Cadastral Editor folder and copy the folder to your local drive.

The tutorial data is now copied to your local drive.

Connecting directly to your tutorial data

Folder connections in ArcCatalog simplify the task of navigating to your most frequently used datasets.

1. On the Standard toolbar in ArcCatalog, click Connect to Folder  Folder
2. In the Connect to Folder dialog, navigate to and select your local copy of the Cadastral Editor tutorial folder.
3. Click OK.

Your new folder connection is now listed in the Catalog tree. You will now be able to access all the data needed for this tutorial through this connection.

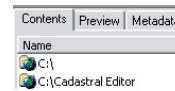

Enabling the Survey Analyst Extension

Before you can begin working with the cadastral editor, you need to enable the Survey Analyst extension:

1. In ArcCatalog, click the Tools menu on the Main Menu toolbar.
2. Click Extensions...
3. Check the Survey Analyst checkbox in the Extensions dialog.

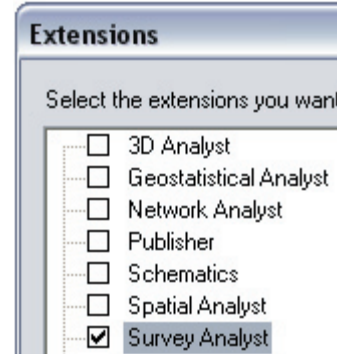

4. Click Close.

The Survey Analyst extension is now enabled.

Exercise 2: Creating and managing a cadastral fabric

In this exercise, you will create a new cadastral fabric dataset. Most cadastral fabrics will use, as a starting point, existing parcel data from GIS and CAD layers. You will migrate existing parcel-based GIS data from Alachua county into your cadastral fabric. Later on in the exercise, you will load the cadastral fabric dataset as a layer into ArcMap.

Creating a new cadastral fabric dataset

Cadastral fabric datasets are created as new nodes under feature datasets in ArcCatalog:

1. In ArcCatalog, click the plus sign next to your new cadastral editor folder connection. Click the plus sign next to the TutorialData folder to expand its contents. Click the plus sign to expand the AlachuaCounty geodatabase.

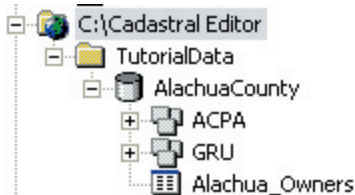

2. Right-click the ACPA feature dataset, point to new and click Cadastral Fabric...

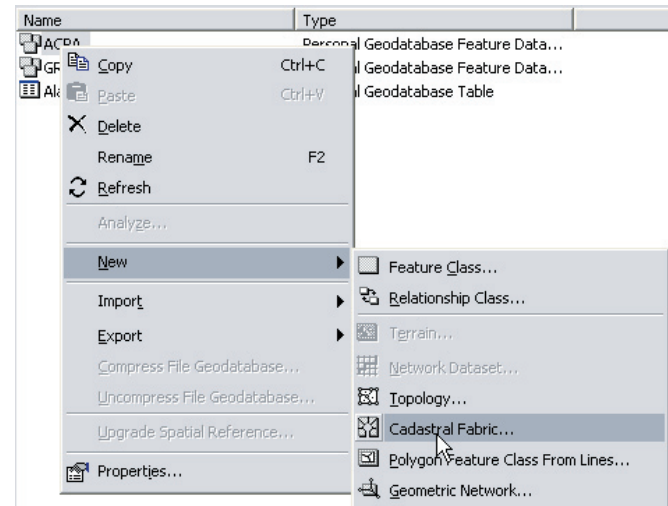

A new cadastral fabric dataset called “NewFabric” will appear as a new node under the ACPA feature dataset.

Migrating data into the cadastral fabric

To migrate parcel-based GIS data successfully into a cadastral fabric, the GIS feature classes need to be aware of the cadastral fabric data model. Cadastral fabric parcel polygons are comprised of a set of lines which have two end points. The cadastral fabric has its own internal arc-node topology. Any GIS data being migrated into a cadastral fabric needs to have arc-node topology. Parcel lines need to be aware of their common endpoints and of their left and right parcel polygons.

1. Double-click the ACPA feature dataset in the AlachuaCounty geodatabase to expand its contents.

There are three parcel-based feature classes: AlachuaParcel_arc, AlachuaParcel_node and AlachuaParcel_polygon.

2. Select each feature class and click the Preview tab in the right-hand pane to view the features.

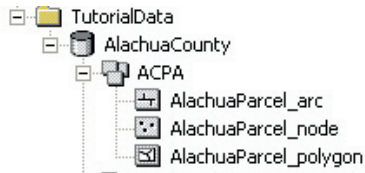

The AlachuaParcel_arc feature class defines the parcel lines that make up the parcel polygons, the AlachuaParcel_node feature class defines the common end-points of the parcel lines and the AlachuaParcel_polygon feature class defines the parcel polygons.

You will now migrate the GIS parcel-based feature classes into your cadastral fabric:

3. Click on the Contents tab in the right-hand pane to switch out of preview mode in ArcCatalog.
4. Right-click the cadastral fabric dataset you just created under the ACPA feature dataset. Point to Import and click Fabric Data

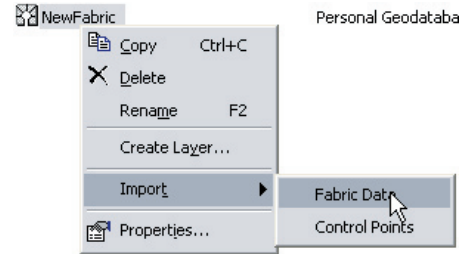

The Cadastral Data Importer wizard appears.

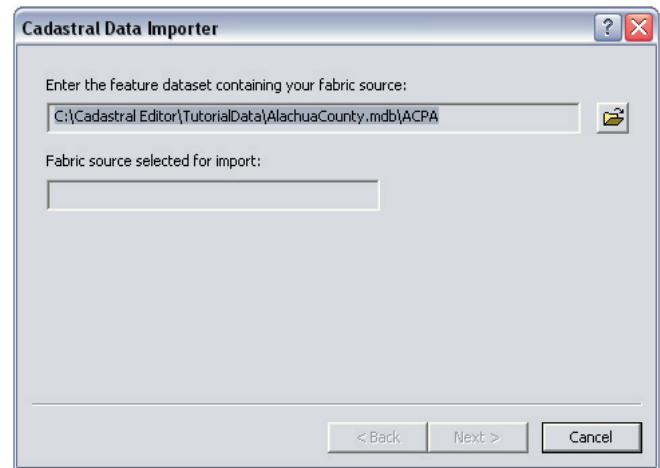

5. Click the open file button  to locate the GIS feature classes containing your fabric source data.

Fabric source GIS feature classes should all have the same name. The parcel lines feature class should be underscored with “_arc”, the parcel polygon feature class should be

underscored “_polygon” and the parcel node feature class should be underscored “_node”.

6. In the Select a COGO feature class to import dialog, navigate to ACPA feature dataset in the AlachuaCounty geodatabase in your cadastral editor\tutorial\data folder. Select the AlachuaParcel_arc feature class.

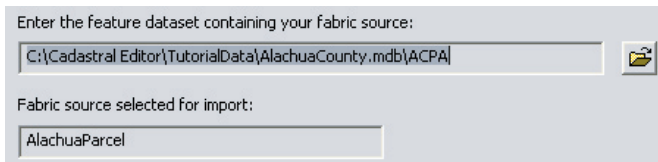

Since all three fabric source feature classes are named the same, you just need to select one fabric source feature class and the importer will identify the remaining two fabric source feature classes.

7. Click Next.

Now you will specify the measurement units of the COGO attributes of your fabric source data. Note that your fabric source data does not necessarily need COGO attributes. If your data has none, the dimension data will be inversed and generated from the shape fields of the fabric source feature classes.

8. Click the drop-down list for Direction and angle units and select Degrees Minutes Seconds. Click the drop down list for Direction type and select Quadrant Bearing.

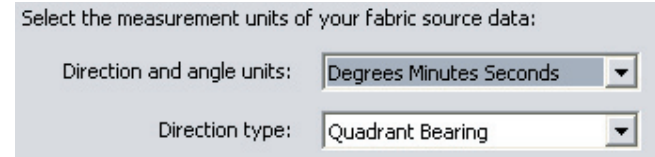

Note that distance units are inherited from the spatial references of the feature classes

9. Click Next.

Now you will set some data migration tolerances for your fabric source data:

10. Enter 5 feet for Radial point tolerance. Radial point tolerance is the maximum amount by which two successive curve radii can vary, for them to be considered the same radius, with the same center point.

Accept the default for the Link to control tolerance. You will import control points in a later exercise.

11. For inversed line accuracy category, leave the default as 6. If your fabric source data has no COGO attributes, the dimension data will be inversed from the shape fields. These parcel lines will be given a low accuracy category.

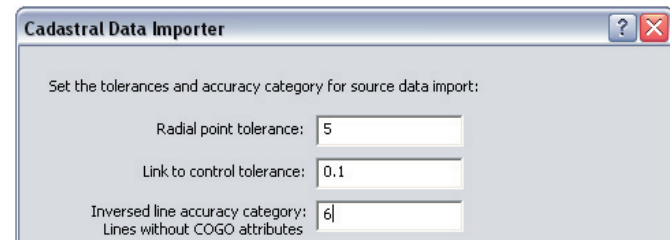

12. Click Next to view the data migration summary.
13. Click Finish to start the data migration process.
14. Once the data migration has completed, click the Preview tab on the right-hand pane in ArcCatalog to preview the data in your cadastral fabric.

Managing your cadastral fabric

The internal tables and feature classes that make up a cadastral fabric act just like normal feature classes in ArcCatalog. You can add attributes to, and create relationship classes with, fabric classes and tables. You can also add subtypes and domains.

You will now create a relationship class between the cadastral fabric and the parcel ownership data for Alachua county.

1. Right-click the ACPA feature dataset, point to New and click Relationship Class...

The New Relationship Class wizard will appear.

2. Type in “FabricParcels_Owners for the name of the relationship class.
3. For the origin feature class, expand the ACPA feature dataset and select NewFabric_Parcels. For the destination table, select Alachua_Owners.

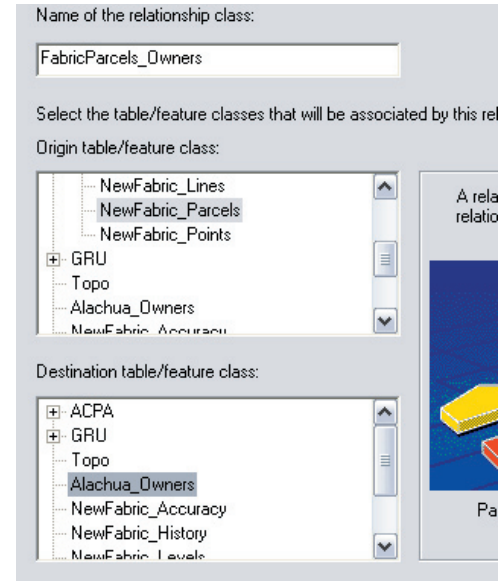

4. Click Next.
5. For the relationship type, keep Simple (peer to peer) relationship selected.

You will notice that Composite relationship is greyed out. This is because a cadastral fabric cannot participate in a composite relationship, where data in a cadastral fabric table could be altered by changes in the related table.

6. Click Next.

7. Accept the default labeling and message propagation settings and click Next.
8. Click 1-M (One to Many) for the cardinality of the relationship class (one parcel can have many owners). Traditionally, you would define a M-N (Many-Many) relationship between parcels and owners but for the purposes of this tutorial, you will define a 1-M relationship
9. You will not add any attributes to the relationship class. Keep the default option selected.
10. Click the drop-down list for the primary key in the origin feature class (NewFabric_Parcels) and select “Name”.
11. Click the drop-down list for the foreign key in the destination table (Alachua_Owners) and select “ID”.

Select the primary key field in the origin table/feature class:

Name

Select the foreign key field in the destination table/feature class that refers to the primary key field in the origin table/feature class:

ID

12. Click Next to view the relationship class summary.
 13. Click Finish.
- The new FabricParcels_Owners relationship class appears under the ACPA feature dataset.

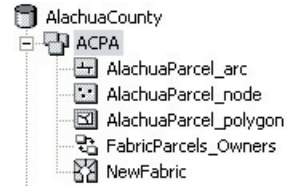

Associating GIS feature classes to your cadastral fabric

When you run a Least Squares Adjustment on your cadastral fabric, new coordinates are computed for the parcel corner points. Parcels in the cadastral fabric will thus adjust over time. GIS features classes that use the parcel boundaries as a basemap, will fall out of alignment with adjusted parcels . The GIS feature class adjustment in the cadastral editor captures the shifts between the old and new coordinates of the adjusted cadastral fabric, and applies these shifts as displacement vectors to GIS feature classes to bring them back into alignment with the adjusted cadastral fabric. To be able to run a GIS feature class adjustment on your GIS data, you need to associate the feature classes to your cadastral fabric.

1. Right-click your cadastral fabric in the ACPA feature dataset and click Properties

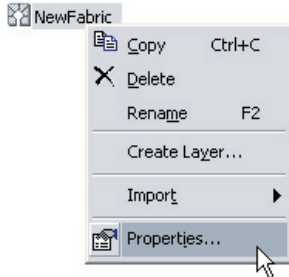

2. In the Cadastral Fabric Properties dialog, click the Associations tab.
3. Click the Add button.

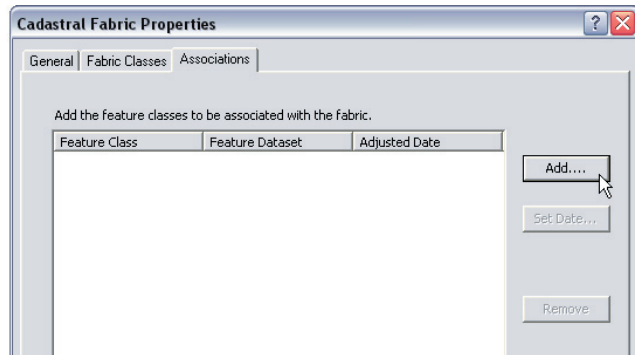

4. In the Associate Feature Classes dialog, navigate to the GRU feature dataset in the AlachuaCounty geodatabase, select the Roads and Buildings feature classes and click Add.

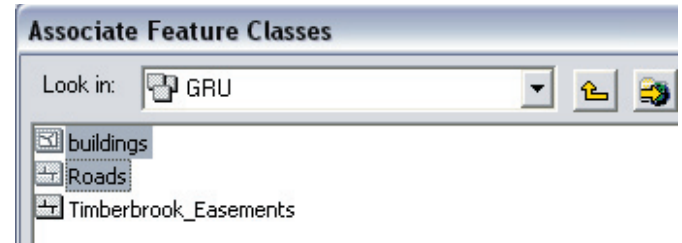

- Both the Roads and Buildings feature classes are now listed as associated feature classes. Note that the adjustment date for both feature classes is set to “Not yet adjusted” until they participate in a GIS feature class adjustment. When the feature classes are adjusted in a GIS feature class adjustment, the adjustment date will be set to the date of the last feature class adjustment.
5. Click OK to close the Cadastral Fabric properties dialog and apply the changes.

Viewing the cadastral fabric in ArcMap

In this section you will add your cadastral fabric dataset as a cadastral fabric layer into ArcMap. The cadastral fabric is loaded as a group layer into ArcMap. The internal feature classes that make up the cadastral fabric are sub-layers under the cadastral fabric group layer. These fabric sublayers can be queried, symbolized and displayed just like normal feature class layers in ArcMap.

1. Open ArcMap by clicking the Launch ArcMap button  on the Standard toolbar in ArcCatalog. Close the “Start using ArcMap with” dialog, if it appears.

2. In ArcMap, click the File menu and click Open...
3. In the Open dialog, navigate to the Cadastral Editor tutorial folder on your local drive.
4. Select the AlachuaCounty ArcMap document in the \Cadastral Editor\ folder and click Open.

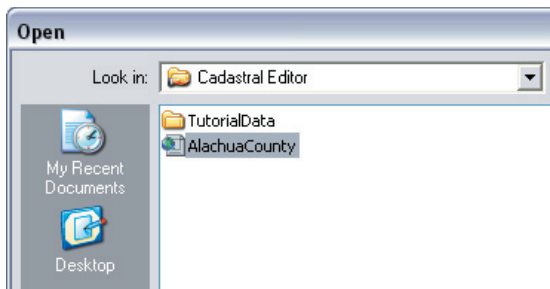

ArcMap displays a map of your cadastral fabric, with the roads and buildings GIS feature classes. The cadastral fabric group layer is made up of the Control, Line points, Points, Lines and Parcels sublayers. These are the internal feature classes that make up the cadastral fabric. The Lines sublayer has several line categories, with each category representing an internal cadastral fabric line type. The radial lines (shown in light grey) are displayed for curved boundaries, and they extend out to the center point of each curve boundary in the cadastral fabric.

For now, turn the display of the GIS feature classes off. We will work with them later:

5. In the table of contents (TOC), uncheck the Buildings and Roads GIS feature classes. Save the map document.

(File -> Save).

You will now use the Identify tool to examine the attributes and relationships of a parcel in the cadastral fabric. First, you need to zoom in a little closer to the area you will be working with:

6. In ArcMap, click the View menu on the Main Menu toolbar, point to Bookmarks and click Timberbrook.

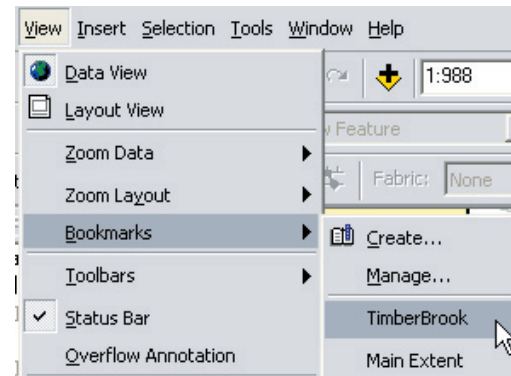

The map display zooms to the extent of the parcels in the Timberbrook survey plan.

7. Click the Identify tool  on the Tools toolbar. (If the Tools toolbar is not present, Click View, point to Toolbars and click Tools.)
8. Using the Identify tool, click on a parcel in the map extent.
9. Make sure NewFabric parcels are selected in the Identify from drop down list.

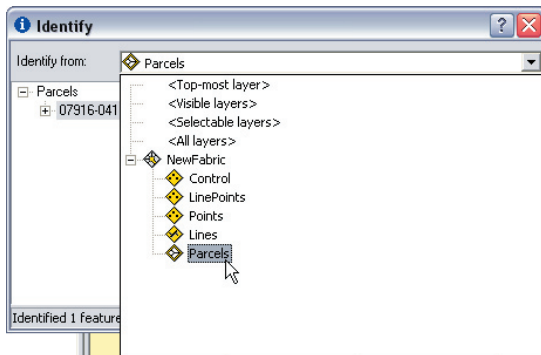

The Identify dialog displays the attributes of the parcel you selected.

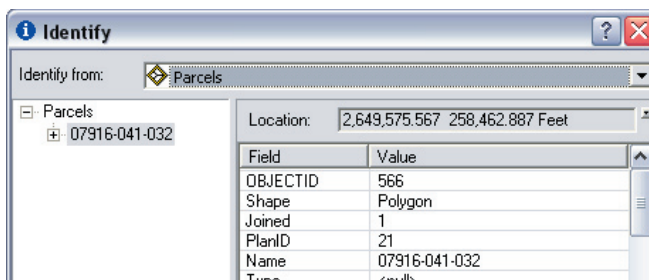

10. Click the plus sign next to the parcel PIN.

The parcel's related lines, plan information and accuracy information appear. The related parcel ownership information (Alachua_Owners) is also displayed. This is from the relationship class you created earlier.

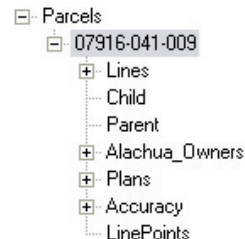

11. Click the plus sign next to Lines to view the parcel lines that make up the parcel polygon.

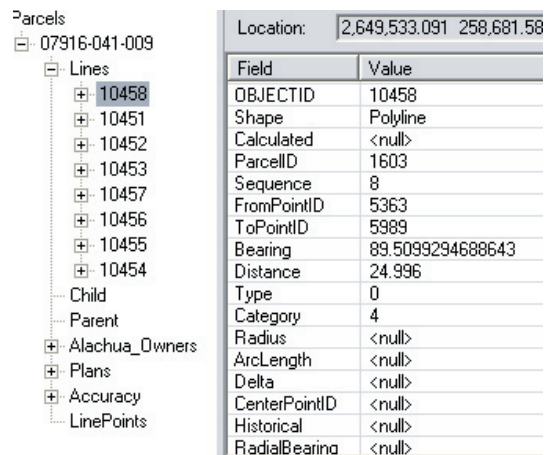

The parcel lines store the survey measurement record information. Each parcel line stores dimension information, which comes from the associated survey plan.

12. Click on each parcel line to view its attributes. The parcel line will also flash green in the map extent.

13. Click the plus sign next to one of the parcel lines

The To and From points of the parcel line is displayed in the Identify dialog The parcel line's associated accuracy information is also displayed.. You can click on the To and From points in the Identify dialog to view their attributes and to flash them on the map screen.

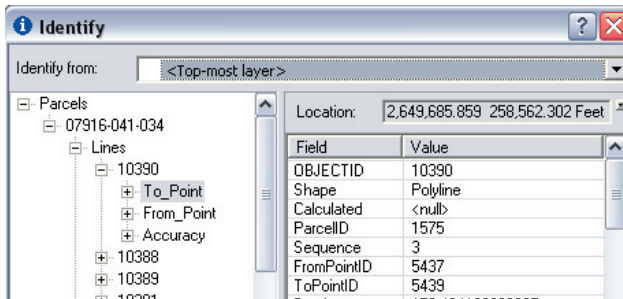

14. Click the plus sign next to Alachua_Owners to view the ownership information for the identified parcel.

15. Click the plus sign next to Plans to view the parcel's associated plan information.

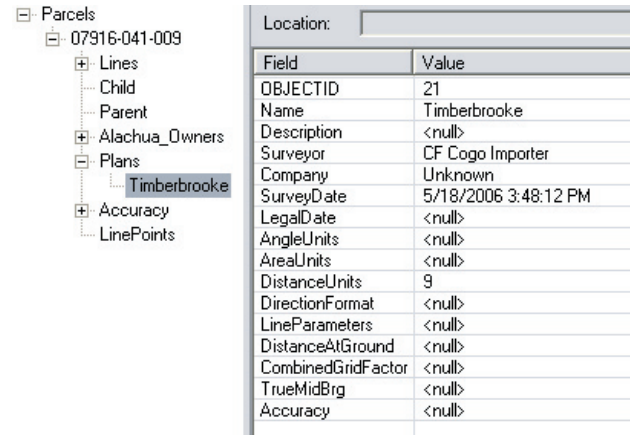

Since the parcel data was migrated, only the Plan name information is displayed. Later on, you will populate the remaining plan attributes.

16. Close the Identify dialog.

Exercise 3: Creating new parcels in fabric jobs

In this exercise you will add a new parcel to the cadastral fabric using a parcel traverse. The new parcel is part of the Timberbrook survey plan. Whenever you edit your cadastral fabric, you need to select and extract the parcels you are working with, out into a fabric job. Fabric jobs are created automatically for you during the extraction process.. You can also manually create a custom fabric job and provide job title, operator and a job description. You will create a custom fabric job in a later exercise.

Modifying parcels in the cadastral fabric

You will be working with parcels from the Timberbrook survey plan. To view this plan, open the Timberbrook PDF file in your Cadastral Editor\TutorialData\ folder on your local drive. You will need Adobe Reader to view this file.

1. If ArcMap is not open, restart ArcMap and open the AlachuaCounty map document.
2. Open the Timberbrook bookmark to zoom to the extent of the Timberbrook survey plan.

Make sure that the Editor and Fabric Editing toolbars are loaded in ArcMap:

4. Click the View menu on the Main Menu toolbar, point to Toolbars and click Fabric Editing. Do the same for the Editor toolbar.
5. Click the Editor menu on the Editor toolbar and click Start Editing to start an edit session.

You will now select the parcels you will be working with and extract them out into a fabric job:

6. Click the Select Cadastral Features tool  on the Fabric Editing toolbar.
7. On the map display, drag a box around the parcels in the area of the Timberbrook survey plan.

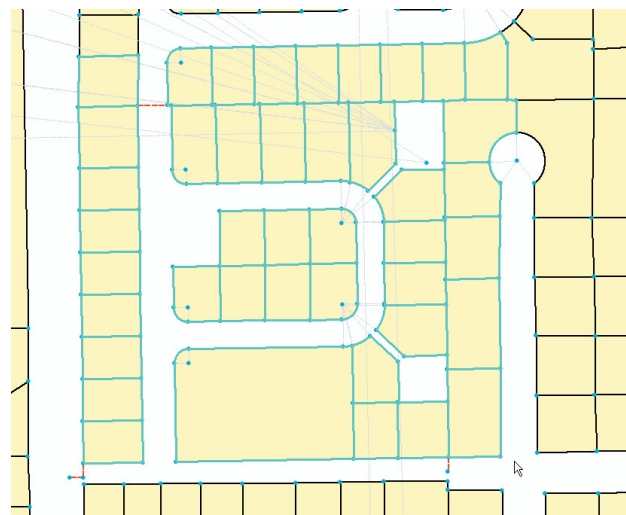

8. Click the Fabric Editing menu on the Fabric Editing toolbar and click Modify...

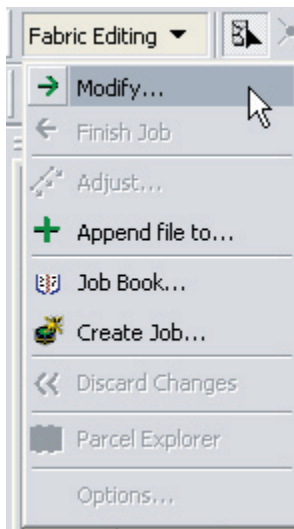

The selected parcels are extracted out to a fabric job and the fabric job is automatically created in the background. The cadastral fabric is now displayed in fabric job mode: The parcels that are part of the fabric job are displayed as active and are available for editing. The parcels outside of the fabric job are displayed as inactive and are not available for editing.

A docked Parcel Explorer window is also displayed on the map, as well as a docked Parcel Properties window.

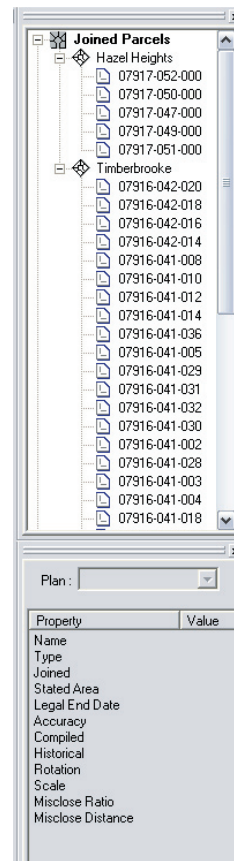

The Parcel Explorer lists all the active parcels in the open fabric job by their associated survey plan. In the fabric job you just created, there are parcels from the Hazel Heights survey plan, and the Timberbrook survey plan.

Entering plan data in the cadastral fabric

Before you create a new parcel in the Timberbrooke survey plan, you first need to set the plan units you will be working with, as well as some other plan information:

1. Right-click the Timberbrook plan in the Parcel Explorer window and click Properties.

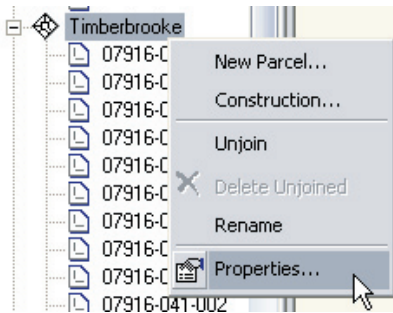

The Plan Properties dialog appears.

2. Click the Record Format tab. Here you will set the units of the Timberbrook plan, and these units will be used when entering parcel data into this plan.
3. Click the Direction or Angle Type drop-down list and select Quadrant Bearing.
4. Click the Direction and Angle Units drop-down list and select Degrees Minutes Seconds.
5. Click the Distance and Length Units and select U.S Survey Feet.

Leave the default selection for Area units , you will not

work with them.

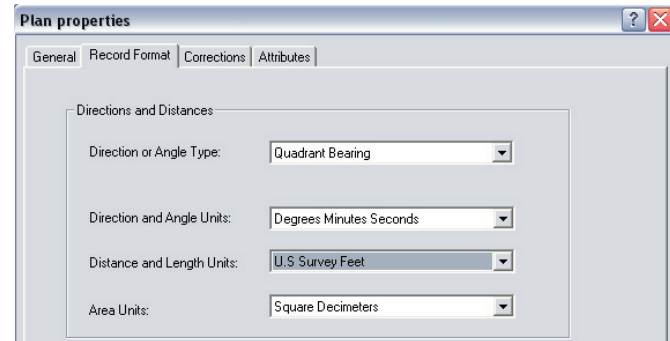

6. For circular curves, click the Circular Curve Parameters drop-down list and select Radius and Arc Length.
7. Click the Circular Curve Direction drop-down list and select Tangent.

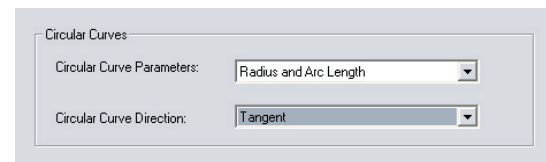

You will now enter some other plan information from the Timberbrook plan:

8. Click on the General tab of the Plan Properties dialog. You can enter the legal description of the Timberbrook plan in the Description text box.

9. Click on the Attributes tab.
10. Enter the Survey Company name and the Survey Date. You can get this information from the Timberbrook PDF file in your \Cadastral Editor\TutorialData folder on your local drive.

Name	Timberbrooke
Description	
Surveyor	
Company	A.K Flowers and Associates
Survey Date	4/29/1995
Legal Date	

11. Click OK on the Plan Properties dialog to apply your changes.

Entering parcel data using the parcel traverse

You will complete the Timberbrook survey plan and enter in the missing parcel:

1. Right-click the Timberbrook plan in the Parcel Explorer, and click New Parcel...

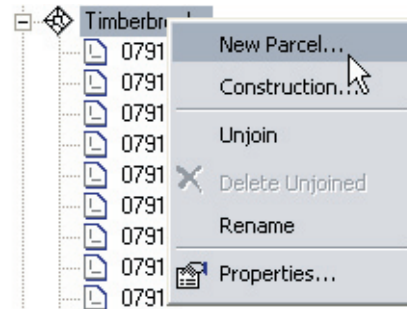

The data frame switches from the open fabric job to a new, blank data frame for parcel editing. You will essentially enter in the parcel data in its own local coordinate space. In most cases, there is no coordinate or spatial reference information on a survey plan, there is only dimension information. Data entry in the cadastral editor is tailored to an environment where only dimensions are known, with no coordinates or spatial reference information.

In the parcel edit data frame in ArcMap, the docked Parcel Properties window has become active.

2. In the Parcel Properties window, make sure the Timberbrook plan is selected.

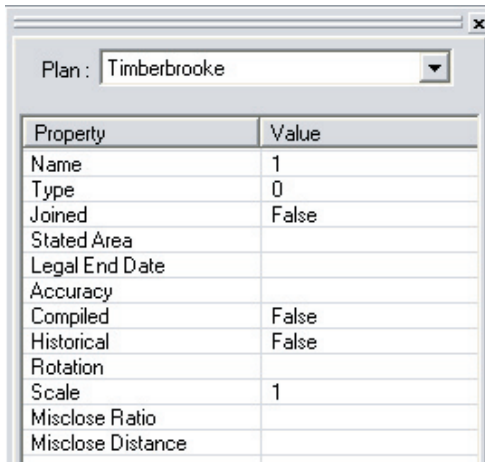

3. Type “07916-041-033” in the empty field next to the parcel Name field and push <Enter> on your keyboard. This is the parcel PIN.

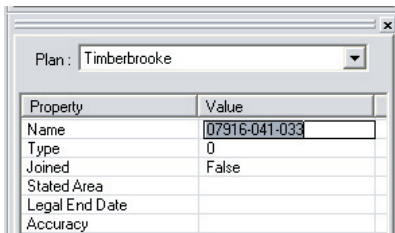

4. Click on the Lines tab of the Parcel Properties window. An empty parcel traverse grid appears. You may need to expand the Parcel Properties window to see the full grid.

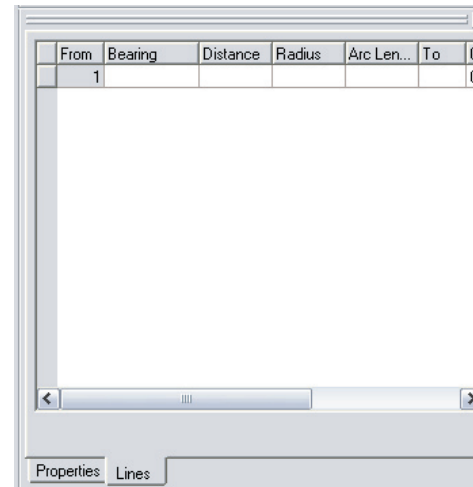

5. Click on the Bearing field to enter the first leg of the parcel traverse. Enter a bearing of “N89-52-06W”. Click Tab to enter a Distance of “82” feet.
6. Push <Enter> on your keyboard to display the first traverse leg in the construction data frame.

You do not need to populate the From and to fields as they are populated automatically.

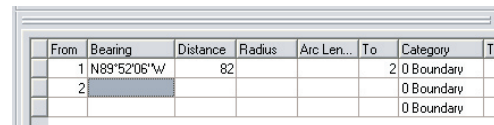

7. Enter in the dimension data for the second parcel traverse leg: Enter a bearing of “N00-13-00E” and a distance of “72.26” feet. You can also enter “00-13-00-1” as an alternative. “1” Being the 1st quadrant.

From	Bearing	Distance	Radius	Arc Len...	To	Category	Tj
1	N89°52'06"...	82			2	0 Boundary	
2	N0°13'00"E	72.26			3	0 Boundary	
3					0 Boundary		
					0 Boundary		

8. Enter in the circular curve dimension data for the third leg of the parcel traverse: Enter a bearing of “N00-13-00E”, a radius of “25” feet and an arclength of “39.23” feet.

From	Bearing	Distance	Radius	Arc Len...	To	Category	Tj
1	N89°52'06"...	82			2	0 Boundary	
2	N0°13'00"E	72.26			3	0 Boundary	
3	N0°13'00"E		25	39.23	4	0 Boundary	
4					0 Boundary		

9. Enter in dimension data for the fourth leg of the parcel traverse: Enter a bearing of “S89-52-06E” and a distance of “57.05” feet.

From	Bearing	Distance	Radius	Arc Len...	To	Category	Tj
1	N89°52'06"W	82			2	0 Boundary	
2	N0°14'39"E	72.26			3	0 Boundary	
3	N0°14'39"E		25	39.32	4	0 Boundary	
4	S89°52'06"E	57.05			6	0 Boundary	
6					0 Boundary		
					0 Boundary		

10. Enter in the fifth and final leg of the traverse to close the parcel. Enter a bearing of “S00-13-00W” and a distance of 97.25” feet. This time you will enter a To point of “1” which is the starting point of the parcel:

From	Bearing	Distance	Radius	Arc Len...	To	Category	Tj
1	N89°52'06"...	82			2	0 Boundary	
2	N0°13'00"E	72.26			3	0 Boundary	
3	N0°13'00"E		25	39.23	4	0 Boundary	
4	S89°52'06"E	57.05			6	0 Boundary	
6	s00-13-00w	97.25			1	0 Boundary	
					0 Boundary		

Once you close the parcel traverse back on its starting point, misclosure information for the parcel is displayed at the bottom of the Parcel Properties window. The misclosure is the difference between the starting point of the first traverse leg and the ending point of the last traverse leg. The parcel misclosure should be as small as possible. The misclosure for the parcel you just entered is 0.0289 feet, which is within acceptable limits.

Misclose: 159°42'11" 0.0289 Acc: 1:11908 Area: 7840.2

Large misclosures indicate either a data entry error, or a problem with the survey data.

11. Click the Save on the Parcel Construction toolbar to save your parcel traverse.

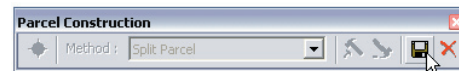

The data frame switches back to the active parcels in your fabric job and the newly created parcel is listed as an unjoined parcel in the Parcel Explorer.



New parcels reside in unjoined space in an open fabric job. Remember, you created your new parcel with no knowledge of coordinates, or of a spatial reference. Your parcel has no knowledge of where it fits in the cadastral fabric. For your new parcel to become part of the cadastral fabric it has to be “fitted” or joined into the cadastral fabric.

Joining a parcel to the cadastral fabric

You will now join your new parcel “07916-041-033” to the cadastral fabric:

1. With the fabric job still open, click the View menu, point to Bookmarks and click Join Timberbrooke Parcel to zoom into the area where you will be joining the parcel.
2. Right-click the unjoined parcel “07916-041-033” and click Join.

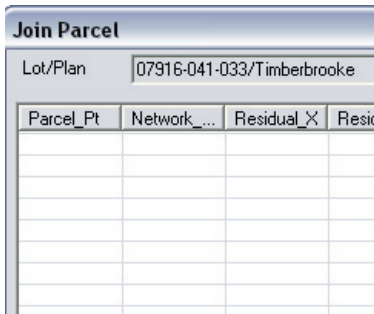

The unjoined parcel appears as a floating geometry in your data extent, and the Join Parcel dialog appears. If necessary, drag the parcel to a position where join lines can be easily constructed between parcel corners.

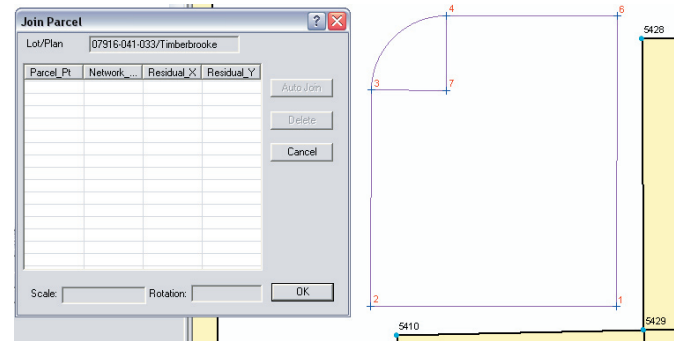

3. To establish your first join line, click on the bottom right corner of the unjoined parcel and then click on its corresponding corner in the cadastral fabric.

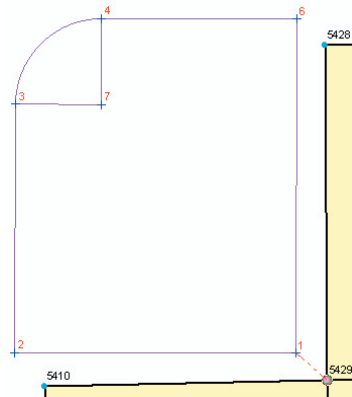

4. Join the bottom left corner.

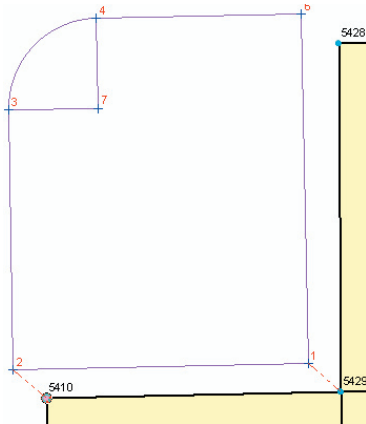

5. Join the top right corner.

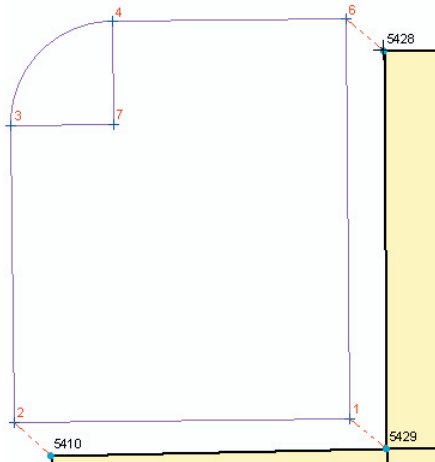

Once you have established three join lines, residuals will appear in the Join Parcel dialog. A scale and rotation is also displayed.

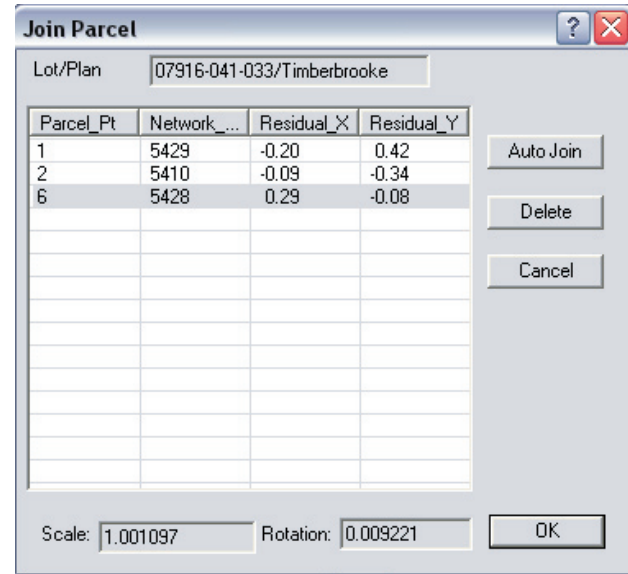

Join residuals are an indication of how well the unjoined parcel fits with the surrounding cadastral fabric parcels. The residuals are derived from a difference in measurements between the joining parcel's boundaries and the adjacent cadastral fabric parcel boundaries. Large residuals are an indication of either an inaccurate cadastral fabric, or of problems in the unjoined parcel data. In this case, the join residuals are acceptable.

6. Click OK on the Join Parcel dialog to join parcel “07916-041-033” to the cadastral fabric.

The data frame will refresh to display your new parcel as one of the active parcels in the fabric job.

To update the cadastral fabric with your changes, the final step is to post the fabric job back to cadastral fabric:

7. Click the Fabric Editing menu on the Fabric Editing toolbar and click Finish Job.



The fabric job changes are posted back to the cadastral fabric.

8. Click the Editor menu on the Editor toolbar and click Save Edits to save the changes to the database (or on SDE, to the version).
9. Stop the edit session. (Editor -> Stop Editing).

Exercise 4 : Working with parcel construction tools

In the previous exercise, you learnt how to add a new parcel to the cadastral fabric using the parcel traverse. In this exercise, you will learn how to create new parcels using existing parcel geometry as a template. Using parcel construction tools, you will split a parcel block into smaller, subdivided parcels. Once again you will edit your parcels in a fabric job.

Using parcel construction tools to subdivide an existing parcel block

For this exercise, you will re-open the fabric job you worked with in the previous exercise. You do not need to re-select and extract parcels out to a fabric job every time you want to edit the cadastral fabric. If you want to work with the same set of parcels already added to a previous job, you can just re-open the existing fabric job from the job book.

1. If ArcMap is not open, re-open the application and load the AlachuaCounty map document.
2. Make sure your map is zoomed out to the correct extent. (View -> Bookmarks -> Timberbrooke).
3. Start an edit session. (Editor -> Start Editing.)
4. Click the Fabric Editing menu and click Job Book... to open the fabric job book.

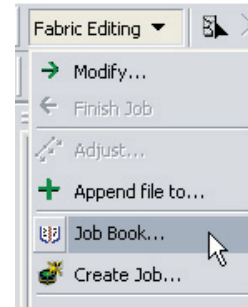

The dockable Job Book window appears on the screen.

5. Re size the Job Book window, if necessary. In the list of fabric jobs, you should see the single fabric job you worked on in Exercise 3.

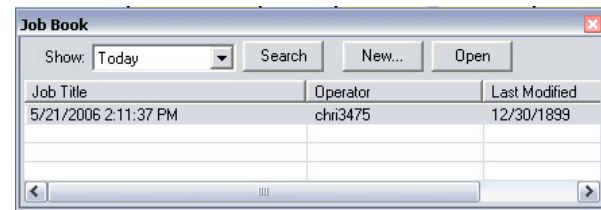

You will re-open this fabric job to continue with your parcel edits.

6. Select the fabric job in the Job Book window and click Open. You can also double-click on the selected fabric job to open it.

The parcels in the selected fabric job are extracted again and re-opened in the fabric job.

7. Close the Job Book.
8. Click on the Select Cadastral Features tool and click on the large, unsubdivided parcel block in the active fabric job. You can also select parcel “07916-041-022” in the Parcel Explorer.

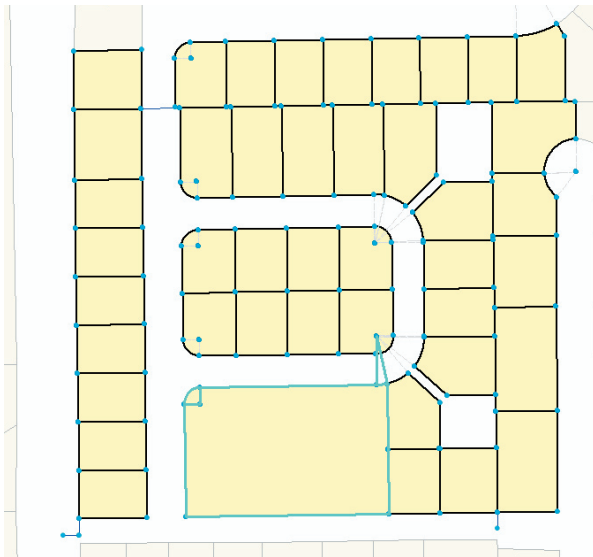

9. Right-click on the selected parcel and click Unjoin. When editing existing parcel geometry or adding new construction lines to an existing parcel, you need to unjoin the parcel from the cadastral fabric.

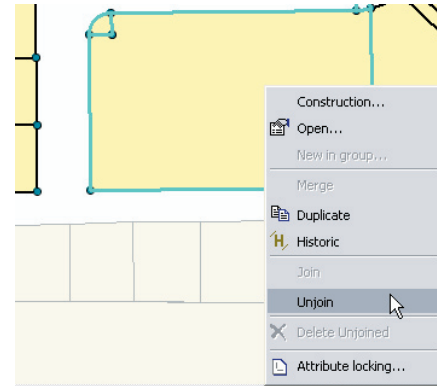

The selected parcel is now listed as an unjoined parcel in the Parcel Explorer.



10. Right-click the unjoined parcel and click Construction...

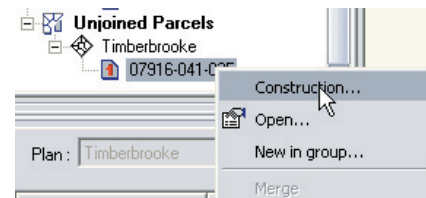

The data frame switches to the parcel edit data frame and displays the parcel’s construction lines. You will now use the parcel breakline construction tool to split the parcel block into its subdivided parcels.

- Right-click on the top-most line on the construction parcel (line going from point 3 to point 5) and click Breakline...

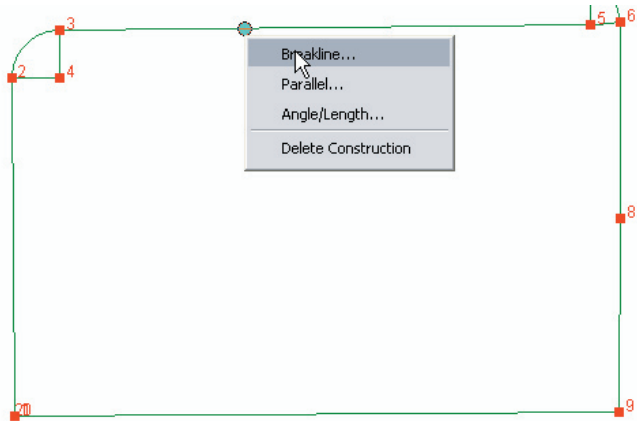

- On the Breakline dialog, click in the first empty line in the Break at distance column and enter “54.03” to create your first breakpoint. Click enter.
- Enter “79.00” on the second line to create your second breakpoint.
- Enter “79.00” for your third and final breakpoint for the line.

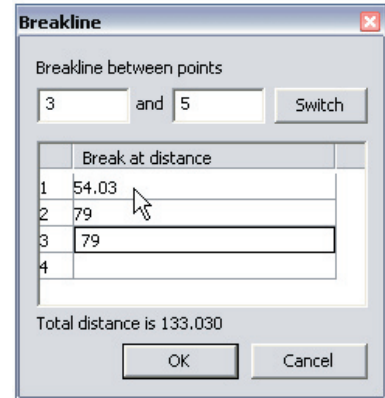

- Click OK. All three breakpoints are created on the parcel line.
- Now right-click the bottom-most parcel line and click Breakline...

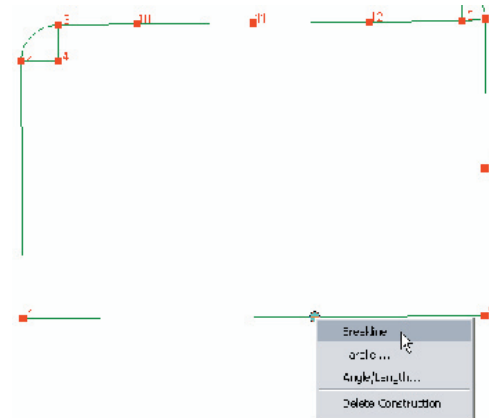

The breakpoints you will enter on the bottom line are all at an equal distance of 79.00 feet.

- Click the Switch button to switch the direction of the breakline. The breakline direction should be between points 1 and 9.
- On the first breakpoint line, enter “79” and then a space and the number “3”. Push Enter on your keyboard.

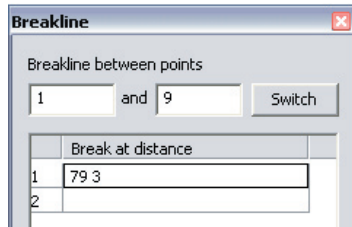

This is a quick method of adding equally spaced breakpoints in succession on a parcel line.

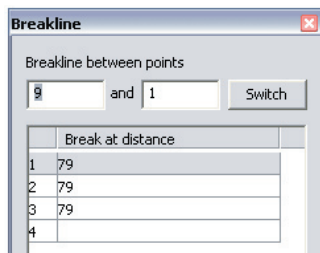

- Click OK to close the Breakpoint dialog. The three new breakpoints on added on the bottom-most parcel line.

You will now add a breakpoint on the left-most line of the parcel block:

- Right-click on the left-most line of the parcel block and click Breakline.

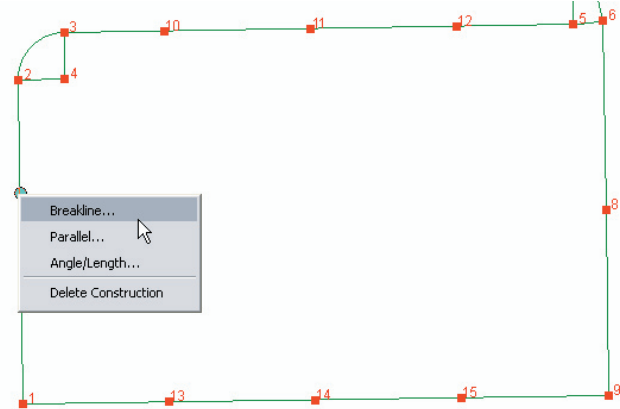

- On the Breakline dialog enter “100”. The breakline must be between points 1 and 2 (breakline going from bottom to top).

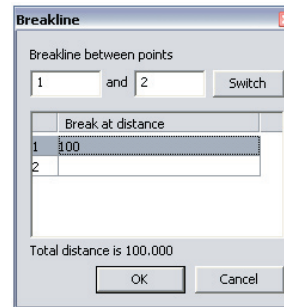

18. Click OK to create the breakpoint.

Your parcel block should now have the following breakpoints:

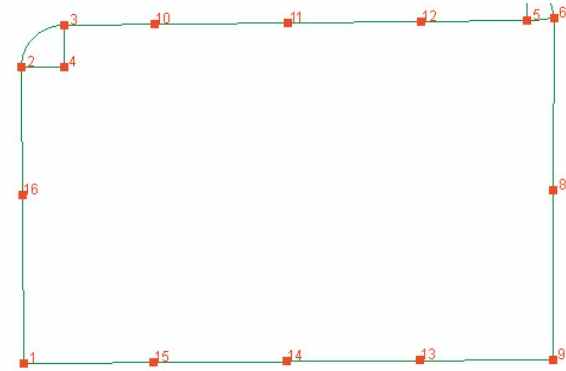

You will now add a construction line between the breakpoints on the left and right parcel lines (between points 16 and 8).

19. Scroll down on the construction line grid and click in From field of the first empty grid line.

From	Bearing	Distance	Radius	Chord	To	Date
3	89.423889	275.17			5	0 Bc
5	83.843056		75.046	16.035	6	0 Bc
6	180.238889	102.045			8	0 Bc
8	180.216667	100			9	0 Bc
9	269.432778	316			1	0 Bc
2	89.418876	25			4	3 De
3	179.491526	25			4	3 De
5	359.256306	75.046			7	3 De
6	346.990360	75.046			7	3 De
						0 Bc

20. Snap on point 16 and then snap on point 8 to construct a line between points 16 and 8.

The construction line's parameters are populated in the construction grid.

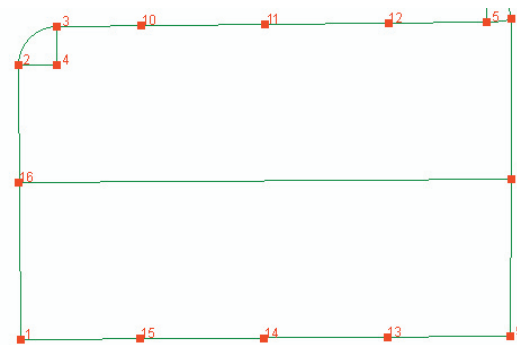

21. Right-click on the line you have just added and click Breakline... to add breakpoints to this line (Breakline between points 16 and 8.)

22. In the Breakline dialog, enter "79 3" to enter three equally spaced breakpoints at 79 feet apart.

Click OK

Your parcel should now have the following breakpoints:

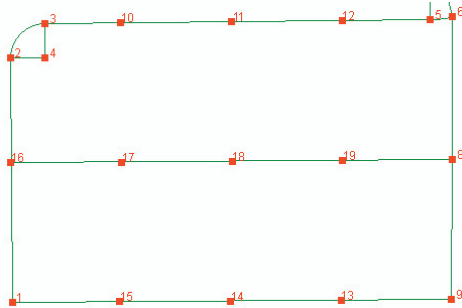

You will now construct vertical lines between the breakpoints to split the parcel block into smaller, subdivided parcels.

23. Scroll down to the bottom of the construction line grid and click in the From field of the first empty line.

24. Snap on breakpoints 10 and 17, 11 and 18, 12 and 19 to add three lines to the top half of the parcel block.

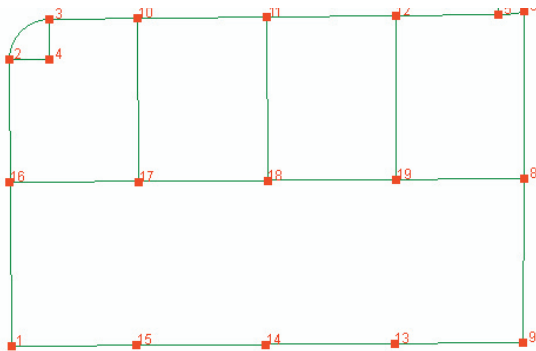

25. Snap on breakpoints 17 and 15, 18 and 14, 19 and 13 to complete the subdivision of the parcel block.

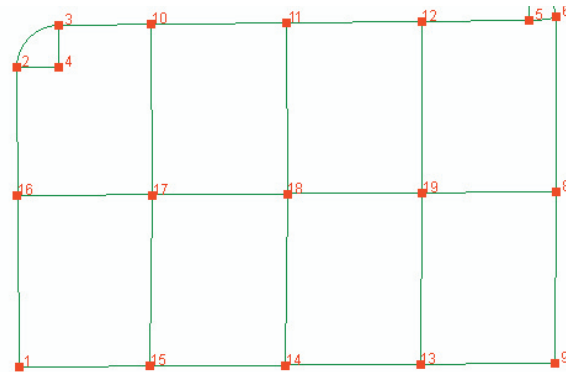

26. Click the Build Parcel  button on the Parcel Construction toolbar to build parcels from the newly added construction lines and points.

27. Click Save on the Parcel Construction toolbar to save the parcels as unjoined.

The newly subdivided parcels are saved as unjoined parcels under a new plan node called New Construction.

28. In the Parcel Explorer, right-click each of the two existing, unjoined parcels under the Timberbrook plan node and click Delete Unjoined to delete each parcel.

Joining a group of parcels to the cadastral fabric

You will now join the newly subdivided parcel group into the cadastral fabric.

1. With your fabric job still open, zoom into the parcel join area on the map.
2. Right-click one of the unjoined parcels in the Parcel Explorer and click Join.

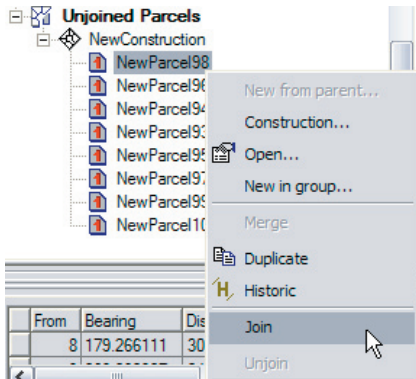

The subdivided parcel group will appear as floating geometry in the data extent.

3. If necessary, drag the parcel geometry to a place where you can easily pair up your join lines.
4. Join the three parcel points on the right end of the parcel group to their corresponding points in the cadastral fabric. Join the top-most parcel curve center point as well.

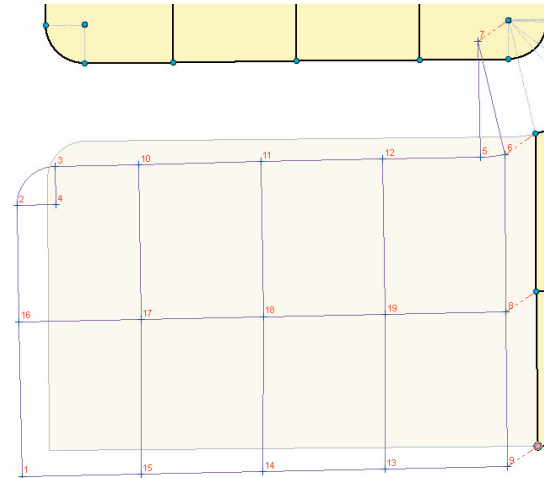

5. Click OK to accept the join lines and to join the parcel group to the cadastral fabric.

If you want to rename the newly joined parcels, right-click the parcel in the Parcel Explorer and click Open... Type a new name for the parcel and click Save on the Parcel Construction toolbar.

6. Click the Fabric Editing menu and click Finish Job to post your changes back to the cadastral fabric.
7. Click the Editor menu and click Save Edits to save your changes.
8. Stop Editing and close ArcMap.

Exercise 5 : Adding control points to your cadastral fabric

In a Least Squares Adjustment of the cadastral fabric, control points are used as a basis for improving the spatial accuracy of all other parcel points in the network. Control points are held as fixed points in the Least-Squares Adjustment and “pin down” or constrain the cadastral fabric at strategic locations. Control points are processed together with the parcel measurements to derive new, more accurate coordinates for connected parcel points in the network.

In this exercise, you will import control points into the cadastral fabric from an existing feature class. Control points can also be entered manually in a fabric job. You will enter a new control point into the Timberbrook survey plan.

Importing control points from a feature class into the cadastral fabric

1. Open ArcCatalog if it is not already open.
2. Open the connection you created to your tutorial data in Exercise 1. Navigate to your cadastral fabric (NewFabric) in the ACPA feature dataset.
3. Right-click on the cadastral fabric, point to Import and click Control Points.

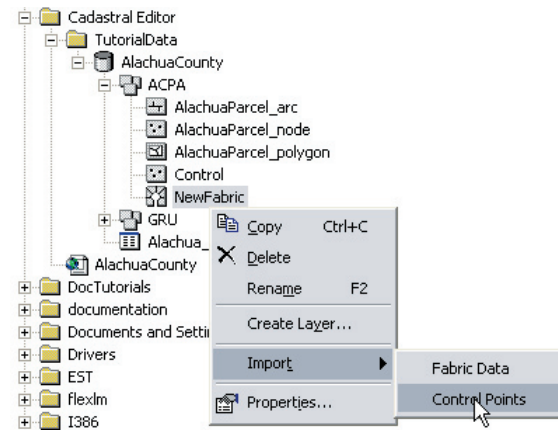

The Cadastral Data Importer wizard will appear.

4. Click the Open File button  and navigate to the Control feature class in the ACPA feature dataset.
5. Select the Control feature class and click Add on the Select a COGO feature class to import dialog.
6. Do not check the Use shape field for coordinates box.

The control feature class has X, Y, Z coordinate attributes and the importer will be using these attribute coordinates. If your control point feature class has no X,Y,Z coordinate attributes, you can check the Use shape field for coordinates box. The importer will then obtain the X,Y, Z coordinates from the shape field of the feature class.

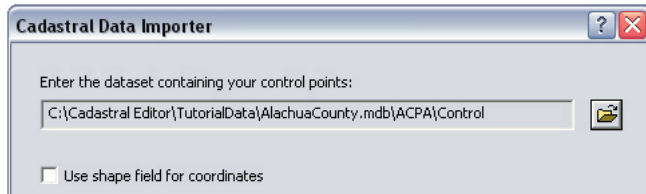

7. Click Next
8. Enter “6” feet for the Link to control tolerance value.

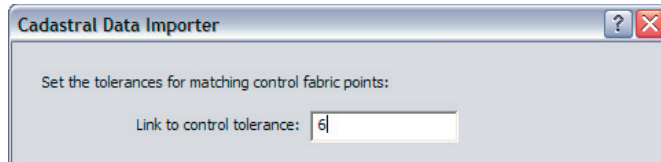

The Link to control tolerance is the tolerance used when matching control points to parcel points in the cadastral fabric. Control points must be linked to a parcel point in the cadastral fabric for connectivity to the network and to be included in the Least Squares Adjustment of the network. If a cadastral fabric is inaccurate, parcel points in the cadastral fabric may not match the locations of their control points. If this is the case, control points can be linked to parcel points that lie within a specified distance (tolerance) of the control points.

9. Click Next to view the import summary and click Finish to import the control points.
10. Open ArcMap and re-open the AlachuaCounty map document in your \cadastral editor\ folder.

The control points should now be visible on the map.

If the importer was unable to find fabric points within the specified tolerance, the imported control points will not be able to participate in a Least-Squares Adjustment. In this case, you can use the manual control point link tool to associate control points to their parcel points.

11. Zoom into the Timberbrooke survey plan on the map (View -> Bookmarks->Timberbrooke)

You will notice that the fabric parcel points do not exactly match the locations of their control points. This is because the control data is more accurate than the parcel data. The fabric points do however, all fall within the specified 6 foot tolerance and are linked to their control points.

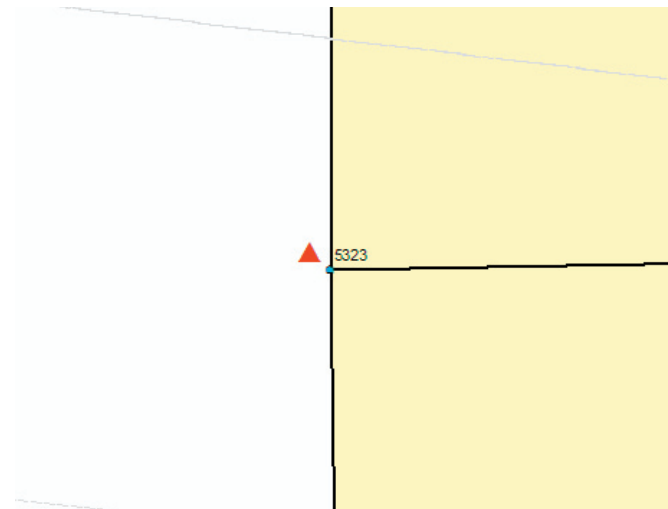

Adding control points manually to the cadastral fabric

In addition to importing control points, you can also manually enter in control points to your cadastral fabric. You will now manually enter a control point from the Timberbrooke survey plan:

1. Click the Editor menu and click Start Editing to start and edit session.

You will add a control point to top-right corner of the Timberbrooke survey plan parcels.

2. Click the Select Cadastral Features tool on the Fabric Editing toolbar and drag a box to select the parcels in the area where you will be adding a control point.

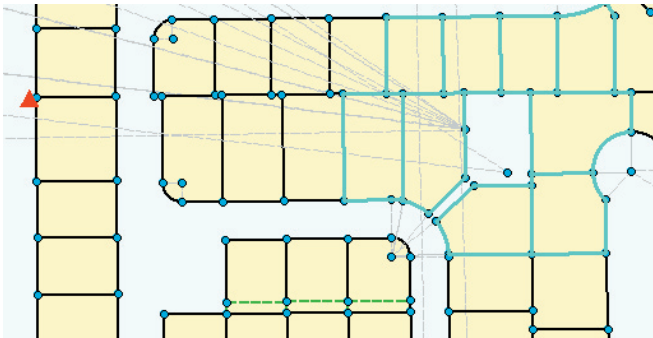

3. Click the Fabric Editing menu and click Modify... to extract the selected parcels into a fabric job.

3. Zoom to the active parcels in the open fabric job.

4. Click on the Maintain control points  button on the Fabric Editing toolbar.

The control dialog will appear on your screen.

5. Click the New button on the Control dialog and click on the top right parcel corner point (point 3042) of the top right parcel in the Timberbrook survey plan.

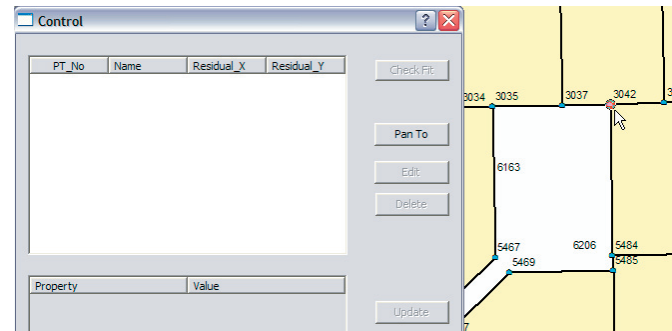

The grid on the Control dialog is populated with the parcel point ID (Associated parcel point ID), a default control point name and the Easting and Northing values from the parcel point. You will re-enter the Easting and Northing values of the control point as the parcel point coordinates do not match the coordinates of the control point.

6. In the Control dialog, click the value of the Easting coordinate and enter the value “2650002.10”. For the Northing value, enter “258807.20”.

Property	Value
Network Point ID	3042
Control Point Name	CP_3042
Easting	2650002.100
Northing	258807.200
Height	0.000
Horizontal Accuracy	

- Click Update to add the new control point to the control points list and to the active fabric job. Close the control dialog.

The control point will appear in its correct location on the map.

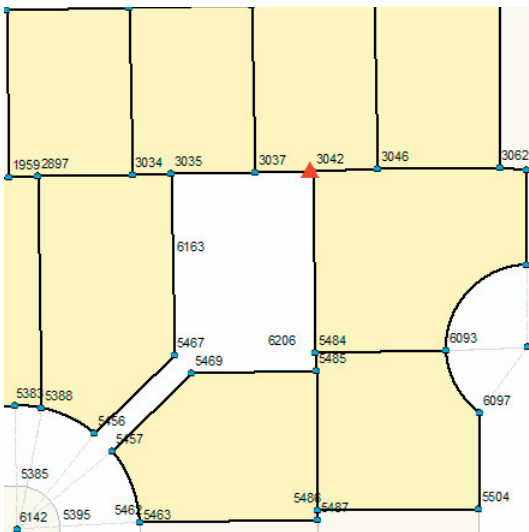

- Click the Fabric Editing menu and click Finish job to post your changes back to the cadastral fabric. Save your edits and stop the edit session.

Exercise 6 : Appending groups of parcels to the cadastral fabric

So far, you have seen how to add new parcel data to a cadastral fabric using the parcel traverse and parcel construction tools. You can also append groups of parcels to your cadastral fabric in the form of XML files. This would be the equivalent of a digital submission of parcels. In this exercise you will append a subdivision of parcels from the Edgewood survey plan.

1. To view the Edgewood survey plan, navigate to your \cadastral editor\TutorialData folder in windows explorer. Open EdgewoodPhase1.pdf

Creating a custom fabric job

1. If ArcMap is not already open, open the application and load the AlachuaCounty map document.
2. Click the View menu, point to Bookmarks and click EdgewoodAppend to zoom the Edgewood survey plan

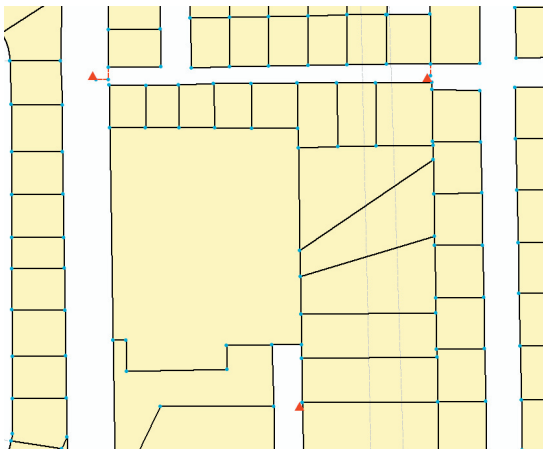

You will create a custom fabric job to append the Edgewood plan parcels:

3. Click the Editor menu and click Start Editing.
4. Click the Fabric Editing menu and click Create Job...

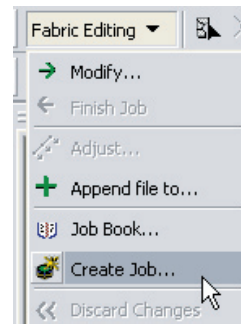

The custom fabric job dialog appears on the screen.

5. In the empty field next to Name, type EdgewoodAppend as the job title.
6. Type an operator name in the empty field next to Owner.

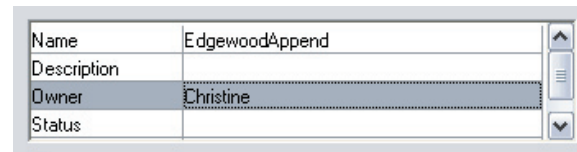

In a custom fabric job, you can exclusively lock the parcels you want to edit. This is relevant on a multi-user, SDE environment. Locked parcels cannot be edited by overlapping jobs.

- Click the Select  Cadastral Features tool on the Fabric Editing toolbar and select the large, unsubdivided parcel on your map extent.

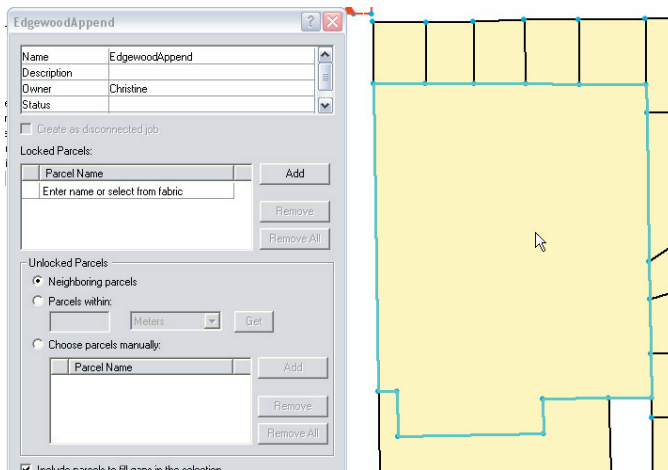

- Click the Add button next to the Locked Parcels list to add the selected parcel as a locked parcel to the custom fabric job.

The parcel name appears in the Locked Parcels list and is displayed in red on the map. For joining purposes, the immediate, surrounding neighboring parcels are added as unlocked parcels to the fabric job. These parcels are displayed in blue and their parcel names are added to the list of unlocked parcels.

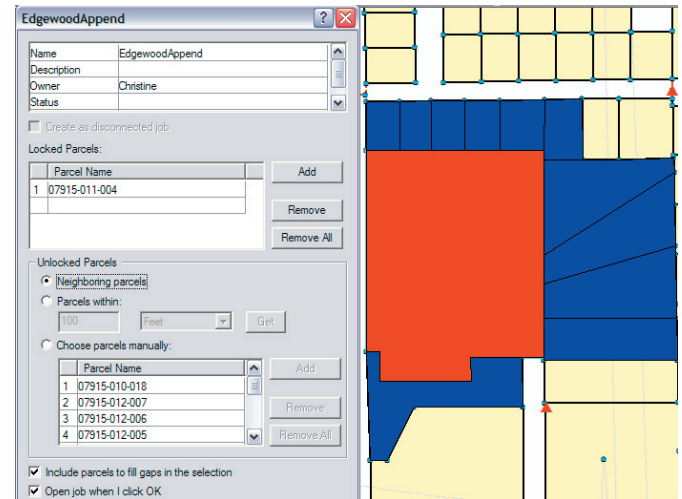

Neighboring parcels are added by default to a custom fabric job. You can add additional surrounding, unlocked parcels using a radius buffer, or by manually selecting parcels.

- Click the Parcels within option and enter a radius of 100 feet.
- Select Feet from the units drop down list.



- Click the Get button.

A radius buffer line is displayed on the map and all parcels intersecting with this line are added as unlocked parcels to the fabric job, and displayed in blue.

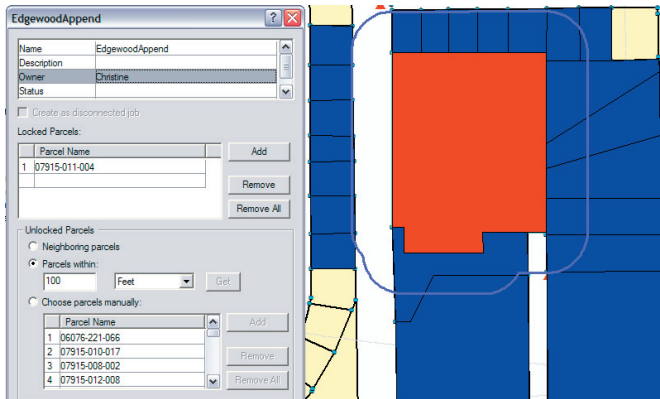

12. Leave the Include parcels to fill gaps in the selection and Open job when I click OK options checked, and click OK to open the fabric job.

The parcels are extracted out into a fabric job. The locked parcel is displayed with a locked icon  in the Parcel Explorer.

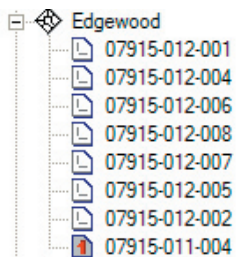

Flagging parcels as historic

Before you append the Edgewood Phase 1 subdivision of parcels to the fabric job, you will mark the existing parcel block as historic.

1. With the fabric job still open, right-click the locked parcel (“07915-011-004”) in the Parcel Explorer and click Historic to turn on the historic flag for the parcel.

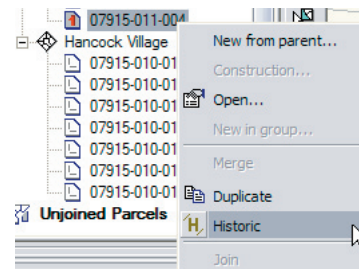

2. Right-click in empty space in the Parcel Explorer and click View Historic Parcels.

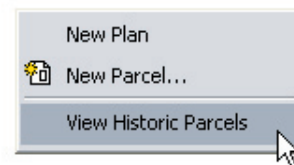

The locked parcel icon changes to the historic parcel icon.

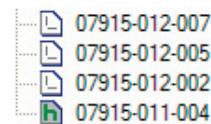

3. Turn the display of historic parcels off. (Right-click in empty space in the Parcel Explorer and click View Historic Parcels)

The historic parcel block is no longer visible on the map.

Appending parcels to a fabric job

1. With the fabric job still open, click the Fabric Editing menu and click Append file...

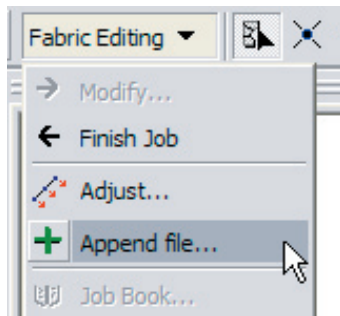

2. In the Open dialog, navigate to your \cadastral editor\ TutorialData\ folder on your local drive and select the EdgewoodPhase1.xml file.

3. Click Open.

The Edgewood1 plan parcels are loaded as unjoined parcels in the fabric job.

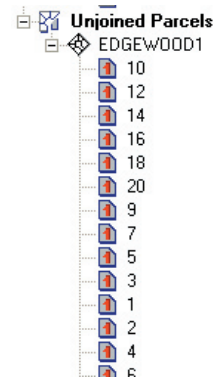

Joining a parcel group to the cadastral fabric

You will now join the Edgewood1 unjoined parcel group:

1. With the fabric job still open, zoom closer into the join area.
2. Right-click any of the unjoined parcels in the Edgewood1 plan and click Join.

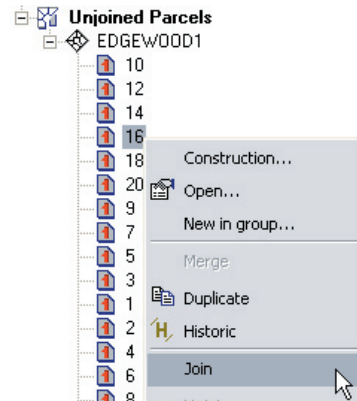

The geometry of the parcel group is floated on the map extent.

3. Click anywhere within the parcel group geometry and drag the geometry to position the unjoined parcel corners for joining.

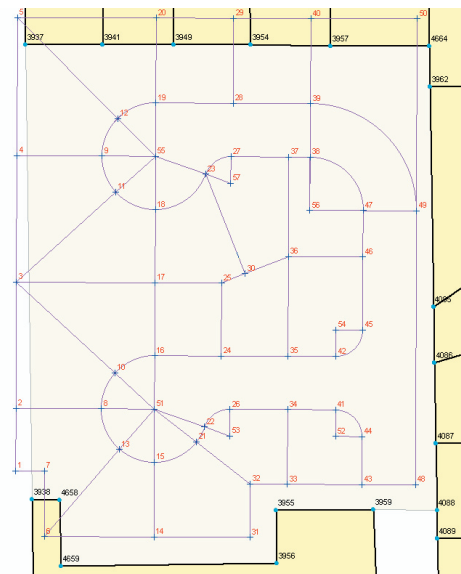

4. Snap on the top left corner of the parcel group and snap on its corresponding corner in the cadastral fabric to create the join line.
5. Join the top right corner.

As you join corners, you can click anywhere within the parcel geometry to move it into positions for easier joining of the parcel corners. You can also zoom in and out.

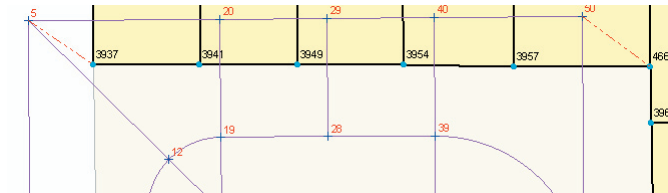

6. Now join the three bottom left corners of the parcel group

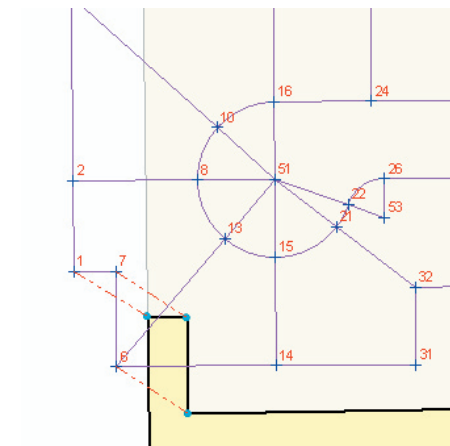

7. Join the bottom four right corners of the parcel group.

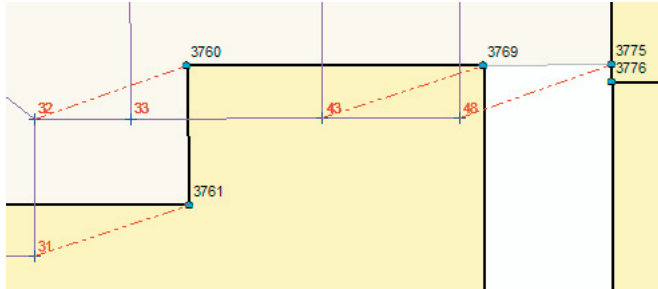

8. Click Auto Join on the Join dialog to pick all remaining join lines

The join residuals are all within acceptable limits

9. Click OK on the Join Parcel dialog to accept the join.

The appended subdivision parcels are now active parcels of the open fabric job.

Post your job changes back to the cadastral fabric:

10. Click the Fabric Editing menu and click Finish job.
11. Click the Editor menu and click Save Edits to save your changes.

Exercise 7 : Adjusting your cadastral fabric

Now that you have added control points to the Timberbrook survey plan, you are able to run a Least Squares Adjustment on the parcels in this area. Least Squares Adjustments are run on the active parcels in an open fabric job. The adjusted parcels are then posted back to the cadastral fabric.

The Least Squares Adjustment processes all the parcel line measurements together with the control points to derive new coordinates for the parcel points. Taking into account the weighting on each parcel line, the adjustment essentially finds a new “best-fit” for the parcel point coordinates. Least Squares Adjustments are typically run after new parcel data or new control has been added to the cadastral fabric. Control points are treated as fixed points in a fabric adjustment and do not shift.

Since the Least Squares Adjustment derives new coordinates for the parcel corner points, adjusted parcel boundaries will shift slightly or significantly, depending on how accurate the original parcel data was in relation to the new survey data and the control points. As the cadastral fabric is adjusted, overlying GIS layers will fall out of alignment with the parcel base map. In this exercise, You will run a GIS feature adjustment to bring your GIS layers back into alignment with your adjusted parcels.

Adding connectivity to a parcel boundary network.

Before you run an adjustment on your parcels, you need to ensure there is good connectivity in the network.

1. If ArcMap is not open, restart the application and open your AlachuaCounty map document in your \Cadastral Editor\ folder. Start an edit session.
2. Zoom to the Timberbrooke survey plan area. (View -> Bookmarks -> Timberbrook)
3. Click the Fabric Editing menu and click Job Book to open the fabric job book.

You will notice 3 jobs now present in the job book. The first job is the automatic job that was created in Exercise 3. The second job is the automatic job that was created when you entered the control point in exercise 5. The third, named job is the custom job you created to append the EdgewoodPhase1 parcels in exercise 6.

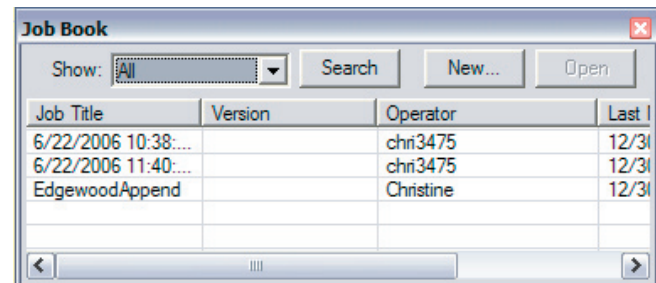

4. In the Job book, select the first job you created in exercise 3. Click Open.

The Timberbrook survey plan parcels are re-opened in the existing fabric job. Notice that the control points are picked up as part of the fabric job as well, since they are linked to parcel points in the fabric job.

5. Close the job book.

When running an adjustment on a group of parcels in a fabric job, you need to ensure that there is sufficient connectivity in the parcel boundary network. There is already a connection line that connects the western strip of parcels to the eastern block of parcels

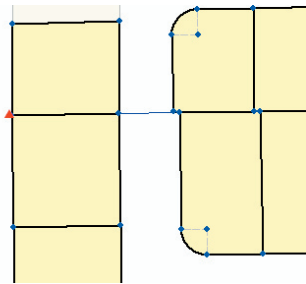

However, this connection line is not sufficient to run an adjustment on a parcel group of this shape and size. More connectivity is needed further south. You will now add one more connection line to the parcel network in the job.

6. Click the View menu, point to Bookmarks and click AddConnectionLine to zoom in closer to the points you will connect.

7. Click the Create Connection tool  on the Fabric Editing toolbar.

8. In the Create Connection dialog, click in the empty box next to “point 1”.
9. Click on the bottom left corner point of the parcel on the right of the empty road space.

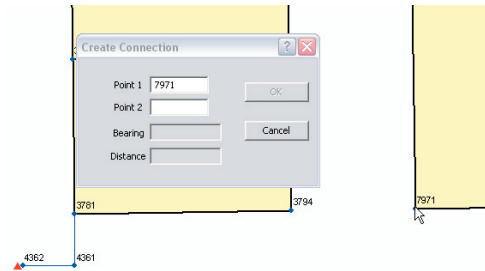

The parcel point ID is added to the empty box in the Create Connection dialog.

10. Click in the empty box next to “Point 2” and click on the bottom right corner point of the parcel on the left of the empty road space.

The bearing and distance of the new connection line is displayed in the Create Connection dialog.

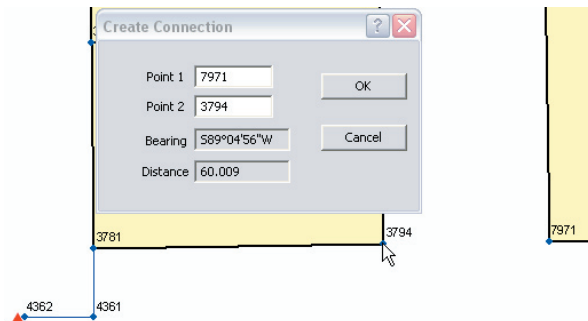

11. Click the OK to create the new connection line.

The map will refresh to display your new connection line.

12. Zoom back out to the extent of the Timberbrook survey plan. (View ->Bookmarks ->Timberbrook)

Running a Least Squares Adjustment on parcels in a Fabric Job

You will now run a Least Squares Adjustment (LSA) on the active parcels in your open fabric job. But first, you need to activate the control points that are part of the fabric job.

1. Click on the Maintain Control Points tool  on the Fabric Editing toolbar.

The Control dialog appears. You will notice that only one control point is active. This is the control point that you entered in exercise 5. The migrated control points are all still inactive.

2. Click the checkboxes next to the three inactive control points to activate them. If a control point is left inactive, it will not be used in the LSA. In this way, you can exclude “bad” control points from the adjustment.

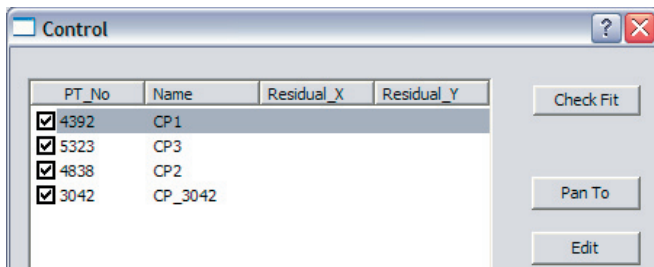

You can click the Check Fit button on the Control dialog to check the fit of your active control points with the existing network. Large residuals indicate that the control point does not fit well with the existing network and may negatively affect the results of the Least Squares Adjustment.

3. Close the Control dialog.

4. For visual purposes, turn on the display of your roads and buildings GIS feature classes in the map. This will give you an idea of the misalignment between the GIS layers and the fabric parcels after the LSA is applied.

5. Click the Fabric Editing menu and click Adjust.

The Adjust Coordinates dialog appears on the screen. You will specify the adjustment tolerances in this dialog before you run the LSA. Adjustment tolerance values are for analysis purposes of the LSA results. Large tolerance values should be entered when adjusting an inaccurate network where much movement and shift is expected in the data. Small tolerances should be used when adjusting an accurate and stable network. Any movement and shift exceeding the tolerance values will be reported in the adjustment report.

6. For the Distances tolerance, enter a value of 1 foot. Enter a value of 1 foot for the tolerances for Line points and Close points as well. Leave the default of 600 seconds for the Bearings tolerance.

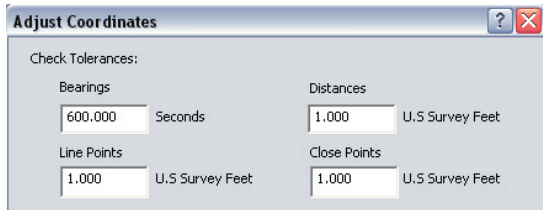

The **Bearings** tolerance is the maximum allowable difference between the line computed in the adjustment and the original measured line. The **Distance** tolerance is the maximum allowable difference between the distance computed in the LSA, and the original measured distance. The **Line Points** tolerance is a check tolerance that flags any line point that lies further away from its line than the specified tolerance. Line points can fail to lie on their lines due to parcel joining. The **Close Points** tolerance is a check tolerance that flags any points that lie closer together than the specified tolerance.

- Under Force Plan Structure, check the Straight lines tolerance check box. The Straight line tolerance enforces the original subdivision structure. A series of lines with the same bearing will be kept collinear, if they lie within the specified tolerance. Enter a value of 1 foot for the Straight lines tolerance.

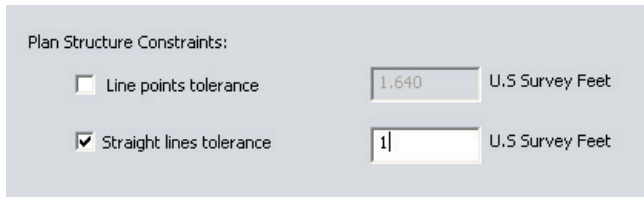

- Leave the default for the remaining options on the Adjust Coordinates dialog and click OK to run the adjustment.

The adjustment completes successfully and displays an overview of the adjustment results. The adjustment finds no close points and no line point errors.

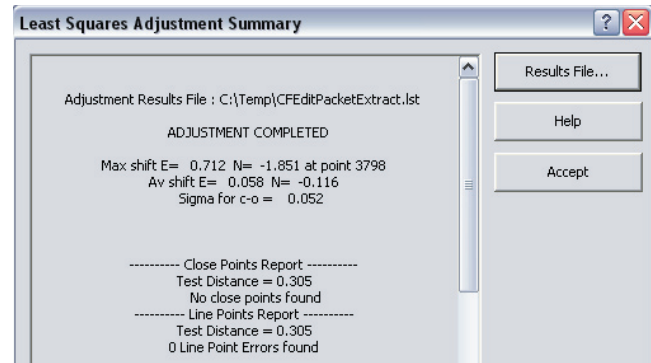

Under the Lines Report, any lines that exceed the specified tolerance for Bearings and Distances is reported.

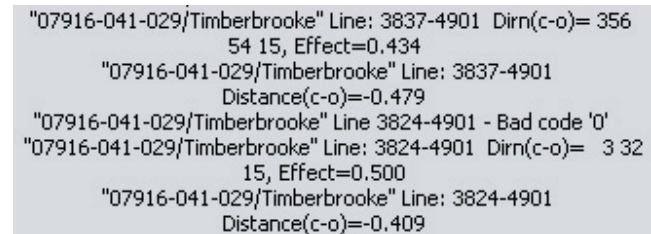

To view the complete adjustment report, click on the Results File button the Least Squares Adjustment Summary dialog.

- Click Accept on the Least Squares Adjustment Summary dialog, to accept the results of the adjustment.

You will notice a slight adjustment in the parcel geometry.

- Zoom in closer to view the shift between adjusted parcel line and the unadjusted parcel lines in the cadastral fabric

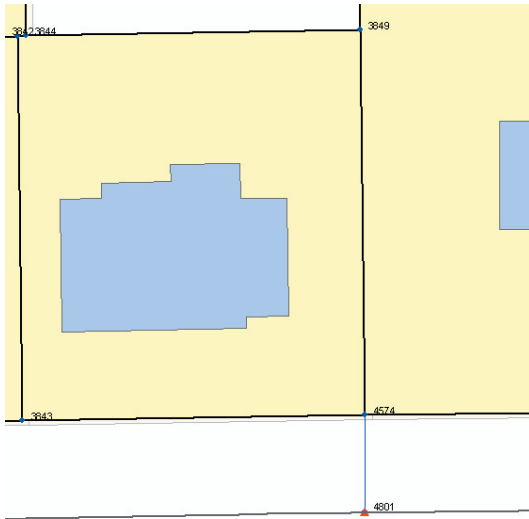

You will also notice that parcel points are now coincident with the location of their linked control points.

- Zoom back out to the Timberbrook extent and post the job back to the cadastral fabric. (FabricEditing -> Finish Job).
- Save your edits.

Adjusting GIS Data using the GIS Feature Adjustment

Now that you have successfully adjusted parcels in your cadastral fabric, you will be able to run a GIS feature adjustment on GIS features in the area of adjustment. In this step, you will adjust the roads and buildings feature classes in the Timberbrook survey plan job extent. You will also associate and adjust the Timberbrook_Easements feature class.

- With ArcMap still open and the edit session still active, right-click on the NewFabric group layer in the TOC and click Feature Adjustment...

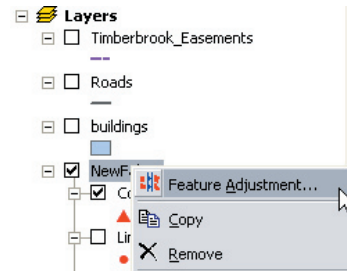

The Feature Adjustment dialog will appear .

- Check the checkboxes for both the buildings and Roads feature classes.

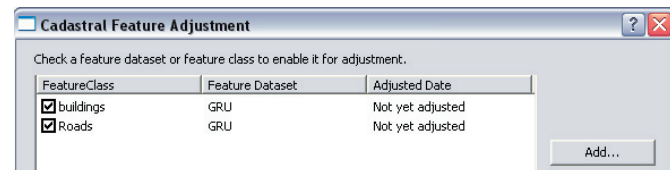

- Click the Adjust button on the Feature Adjustment dialog to run the feature adjustment.

Once the feature adjustment completes you will notice a slight adjustment in both the roads and the buildings feature classes.

You will now associate the Timberbrook_Easements feature class to the cadastral fabric and adjust the easement data. You will first load the Timberbrook_Easements feature class into the map.

- Click the Add Data  button on the Standard toolbar.
- In the Add Data dialog, navigate to the Timberbrook_Easements feature class in the GRU feature dataset.
- Click Add to display the Timberbrook_Easements feature class on the map.
- Right-click the NewFabric group layer in the TOC and click Feature Adjustment.

You will now notice that the Adjusted Date for both the roads and buildings feature class has been set to the date and time when the Least Squares Adjustment was run. This date and time is known as the adjustment level.

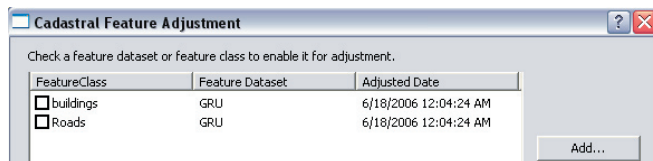

- Click the Add.. button on the Feature Adjustment dialog.
- Navigate to, and select the Timberbrook_Easements feature class in the GRU feature dataset. Click Add.

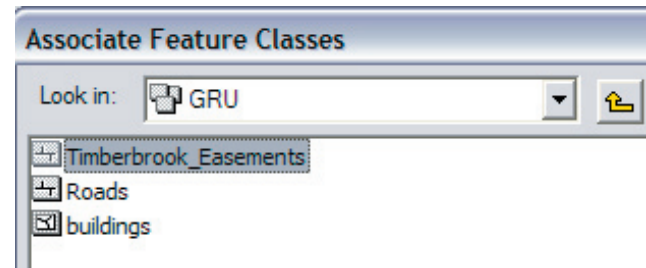

The Timberbrook_Easements feature class is added to the Cadastral Feature Adjustment dialog and its adjusted date is set to “Not Yet Adjusted”.

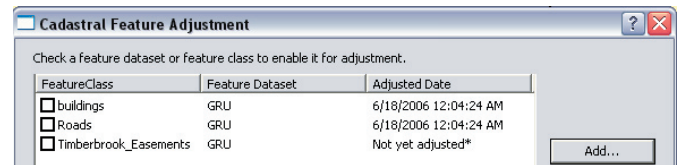

- Check all three feature classes to participate in the adjustment.

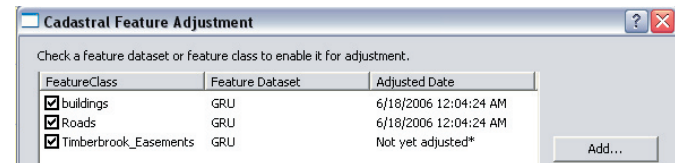

11. Click the Adjust button to rerun the feature adjustment.

You will notice that only the Timberbrook_Easements feature class is adjusted. That is because the roads and buildings feature classes are already at the most current adjustment level and are not re-adjusted with this adjustment. If you re-open the Cadastral Feature Adjustment dialog, you will notice that the Adjusted Date for the Timberbrook_Easements feature class is now the same as the Adjusted Date for the roads and buildings feature classes.

10. Save your edits and close ArcMap.

Congratulations, you have completed the tutorial!